



COMMERCIAL
TRANQUILITY® 18 (SC) COMPACT SINGLE-STAGE SERIES

PRODUCT CATALOG

Part#: LC3000 | Revised: January 13, 2025

Models: SC 006-060
60 Hz - R-454B

Table of Contents

Models:
SC
006-060

3	Introduction	39	Correction Tables
4	Features, Options, and Accessories	40	Antifreeze Correction Table
5	iGate 2 Communicating Controls Powered by CXM2 Communicating Controls	42	Blower Performance
6	iGate 2 Communicating Controls Powered by DXM2.5 Advanced Communicating Controls	54	Physical Data
7	iGate 2 Communicating (AWC) Thermostat	55	Dimensional Data
8	myUplink: Web and Mobile Interface	59	Corner Weights
11	Model Nomenclature	61	Horizontal Service Access
12	Performance Data: ASHRAE/AHRI/ISO 13256-1	64	Vertical Service Access
14	Performance Data: Selection Notes	65	Minimum Installation Area
15	Performance Data	66	Electrical Data
38	CV EC Motor Limits	68	Engineering Specifications
		78	Revision History

THE TRANQUILITY® 18 (SC) COMPACT SINGLE-STAGE SERIES

The Tranquility 18 (SC) Compact Series raises the bar for water-source heat pump efficiencies, features, and application flexibility. Not only does the Tranquility SC exceed ASHRAE 90.1 efficiency standards, but it also uses R-454B low Global Warming Potential (GWP) refrigerant, making it an extremely environmentally friendly space conditioning product solution. Tranquility SC is eligible for LEED® (Leadership in Energy and Environmental Design) points due to its innovative and environmentally-conscious design. With one of the smallest cabinets in the industry, the Tranquility SC easily fits into tight spaces. Designed to be backward compatible with thousands of older water-source heat pumps, the Tranquility 18 (SC) Compact Series heat pump is packed full of the innovation you have come to expect from the experts at ClimateMaster.

Available in sizes from ½ ton (1.8 kW) through 5 tons (17.6 kW) with multiple cabinet options (vertical upflow and horizontal) the Tranquility SC offers a wide range of units for most any application. The Tranquility SC has an extended range refrigerant circuit, capable of geothermal ground loop applications (with optional extended range insulation) as well as boiler-tower water loop applications. Standard features include: scroll compressors, microprocessor controls, galvanized steel cabinet, polymer drain pan and sound absorbing air handler insulation are just some of the features of the Tranquility SC.

Recent EPA mandates require an industry transition to low-GWP refrigerants, such as R-454B which is a gas that is classified as having low-toxicity, low-flammability rating. Due to these characteristics, R-454B systems charged with over 62 ounces of refrigerant must contain an integrated Refrigerant Detection System (RDS). In the unlikely event of a system-refrigerant leak, the RDS shuts down compressor operation and runs the unit blower motor to disperse any concentration of leaked refrigerant in compliance with UL 60335-2-40 safety standards. For Tranquility SC products, only the 5 ton size (060) is required to have the RDS and the feature is optional on all other sizes.

ClimateMaster's double isolation compressor mounting system makes the Tranquility SC one of the quietest units on the market. Compressors are mounted on specially engineered sound-tested EPDM grommets to a heavy gauge mounting plate, which is further isolated from the cabinet base with EPDM grommets to minimize vibration transmission and to maximize sound attenuation. The easy access control box and large access panels make installing and maintaining the unit easier than other water-source heat pumps currently on the market, proving that a small unit can be easy to service.

Options such as tin-plated air coil, DDC controls, and high efficiency pleated MERV-rated air filters allow customized design solutions. Two tiers of Electronically Commutated (EC) fan motor options allow for premium efficiency at a budget price with a Constant Torque (CT) EC or maximized airflow control with an intelligent Constant Volume (CV) EC. Cupronickel water-coils and ClimateMaster's industry-leading sound attenuation UltraQuiet package are options that make a great unit even better.

iGate® 2 technology provides technicians an interface into the operation of the system in real time without the need for hard tooling. On-board advanced controls communicate the key operating system temperatures enabling technicians to startup, commission, and service the equipment remotely by smart phone or website via the cloud. Communication can also be done at the unit via a communicating thermostat or handheld service tool. Not only does iGate 2 monitor current performance, it also allows the functionality to make system adjustments and captures operating conditions at time of fault. All this information is displayed in an easy-to-read format maximizing the usability of the experience.

The Tranquility 18 (SC) Compact Series water-source heat pumps are designed to meet the challenges of today's HVAC demands with one of the most innovative products available on the market.

FEATURES

- Sizes 006 (½ ton, 1.8 kW) through 060 (5 tons, 17.6 kW)
- Exceeds ASHRAE 90.1 efficiency standards
- Environmentally-friendly R-454B low-GWP refrigerant
- Refrigerant Detection System (RDS) (mandatory on size 060, optional feature for sizes 006-048)
- Coaxial heat exchanger
- Galvanized-steel cabinet construction
- Sound-absorbing glass-fiber insulation
- Unique double-isolation compressor mounting for quiet operation
- Insulated divider and separate compressor/air handler compartments
- TXV metering device
- Microprocessor controls with on-board fuse and emergency shutdown
- Field-convertible discharge-air arrangement for horizontal units
- PSC three-speed fan motor (two-speed for 575V)
- Unit Performance Sentinel performance-monitoring system
- Eight standard safety features
- Non-corrosive polymer drain pan
- External Connecting Port on front-left corner post facilitates service tool connectivity, thereby reducing startup, commissioning, and service time
- CXM2 Communicating Controls:
 - Multiple communication pathways for unit access and diagnosis:
 - Cloud-based remote monitoring via iGate 2 Communicating (AWC) Thermostat
 - Connect directly to the system with a handheld service tool
 - Provides real-time unit operating conditions
 - Reduces startup, commissioning, and service time by providing key system temperatures electronically
 - Captures operating conditions in the event of a safety shutdown

OPTIONS

- High-efficiency EC blower motors:
 - Intelligent Constant Volume (CV) EC motors for ultimate airflow control
 - Entry-level Constant Torque (CT) EC motors provide efficiency at a value
- DXM2.5 Advanced Communicating Controls:
 - Includes all of the CXM2 features
 - Dial in desired airflows for CV EC blower motors
- BACnet, Modbus, and Johnson Controls N2 compatibility options for Building Management Systems (BMS)
- Corrosion-resistant cupro-nickel water heat exchanger
- UltraQuiet sound-attenuation package
- Tin-plated air coils for added protection from formicary corrosion
- Easy-to-clean rust-prohibitive stainless-steel drain pans
- Extended-range insulation for geothermal applications
- Electrical-service disconnect

ACCESSORIES

- iGate 2 Communicating (AWC) Thermostat with color touchscreen
- Wide variety of thermostat options to meet your application needs
- Braided-hose kits in various lengths with optional water valve, PT plugs, blowdown valve, flow regulator, and strainer
- Externally-mounted manual and motorized water valves
- 1-inch Merv 8 filter
- 2-inch Merv 8 or 13 filters
- Aesthetically-pleasing wall sensors for connection to BMS (MPC) controls

iGate 2 Communicating Controls Powered by CXM2 Communicating Controls

Models:
SC
006-060

iGATE 2 COMMUNICATION – CLOUD CONNECTED, WEB-ENABLED INFORMATION GATEWAY TO MONITOR, CONTROL, AND DIAGNOSE YOUR SYSTEM

iGate 2 Communication – Cloud connected, web-enabled information gateway to monitor, control, and diagnose your system.

The Tranquility SC is equipped with industry-first, iGate 2 communication information gateway that allows users to interact with their water-source system in easy to read clear language.

Monitor/Configure – Installers can configure from the myUplink PRO website, mobile app, AWC Thermostat, or diagnostic tool, including: Unit family, size, accessory configuration, and demand reduction (optional, to limit unit operation during peak times). Users can look up the current system status: temperature sensor readings and operational status of the blower.

Precise Control – The new CXM2 enables intelligent, two-way communication between the CXM2 and smart components like the AWC Thermostat and diagnostic tool. CXM2 Communicating Controls uses information received from the temperature sensors to precisely control operation to deliver high efficiency, reliability and increased comfort.

Diagnostics – iGate 2 takes diagnosing water source heat pump units to a next level of simplicity, by providing a dashboard of system and fault information, in clear language, on the AWC Thermostat, handheld service tool and the web portal/mobile app on the internet.

iGate 2 Service Warnings notify the homeowner and contractor of a fault and displays fault descriptions by app notifications/email with possible causes. Additionally, the current system status can be viewed graphically on the web portal and mobile app.

In iGate 2 Service Mode, the service personnel can access fault description, possible causes and most importantly, the conditions (temp, flow, i/o conditions, configuration) at the time of the fault. Manual Operation mode allows the service personnel to manually command operation for any of the thermostat outputs, blower speed, to help troubleshoot specific components. This operation can either be conducted at the unit with a communicating thermostat/diagnostic tool or remotely with mobile app/website when the AWC Thermostat controls are used.

With an iGate 2 communicating system, users and contractors have a web-enabled gateway to system information never before available and exclusive to ClimateMaster products.

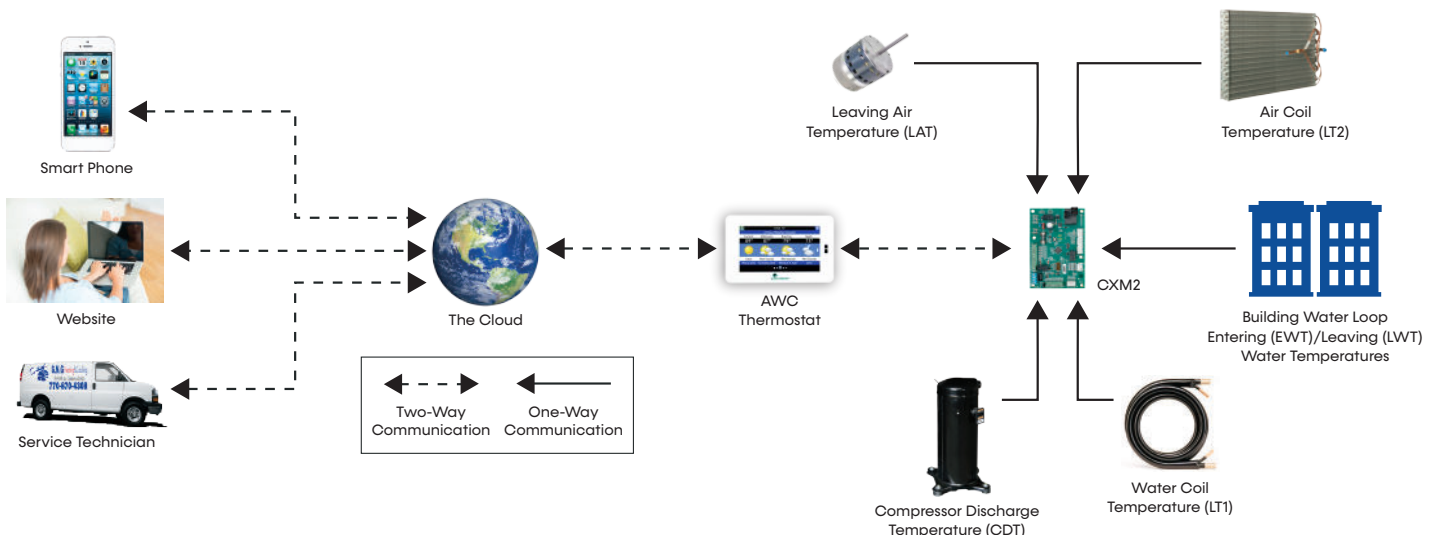

ClimateMaster works continually to improve its products. As a result, the design and specifications of each product at the time of order may be changed without notice and may not be as described herein. Please contact ClimateMaster's Customer Service Department at 800-299-9747 for specific information on the current design and specifications. Statements and other information contained herein are not express warranties and do not form the basis of any bargain between the parties, but are merely ClimateMaster's opinion or commendation of its products. The latest version of this document is available at www.climatemaster.com. Engineered and assembled in the USA. © ClimateMaster, Inc. All Rights Reserved 2024

iGate 2 Communicating Controls Powered by DXM2.5 Advanced Communicating Controls

Models:
SC
006-060

iGATE 2 COMMUNICATION – CLOUD CONNECTED, WEB-ENABLED INFORMATION GATEWAY TO MONITOR, CONTROL, AND DIAGNOSE YOUR SYSTEM

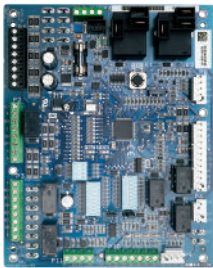

The Tranquility SC is equipped with industry-first, iGate 2 communication information gateway that allows users to interact with their water-source system in easy to read clear language AND delivers improved reliability and efficiency by precisely

controlling smart components.

Monitor/Configure – Installers can configure from the myUplink PRO website, mobile app, AWC Thermostat, or diagnostic tool, including: airflow, unit family, size, accessory configuration, and demand reduction (optional, to limit unit operation during peak times). Users can look up the current system status: temperature sensor readings and operational status of the blower.

Precise Control – The DXM2.5 enables intelligent, two-way communication between the DXM2.5 and smart components like the communicating thermostat/diagnostic tool and constant volume CV EC blower motor. DXM2.5 Advanced Communicating Controls uses information received from the smart components and temperature sensors to precisely control operation of the variable speed CV EC fan to deliver higher efficiency, reliability and increased comfort.

Diagnostics – iGate 2 takes diagnosing water source heat pump units to a next level of simplicity, by providing a dashboard of system and fault information, in clear language, on the AWC Thermostat, handheld service tool and the web portal/mobile app on the internet.

iGate 2 Service Warnings notify the homeowner and contractor of a fault and displays fault descriptions by app notifications and email with possible causes. Additionally, the current system status can be viewed graphically on the web portal and mobile app.

In iGate 2 Service Mode, the service personnel can access fault description, possible causes and most importantly, the conditions (temp, flow, i/o conditions, configuration) at the time of the fault. Manual Operation mode allows the service personnel to manually command operation for any of the thermostat outputs, blower speed, to help troubleshoot specific components. This operation can either be conducted at the unit with a diagnostic tool or remotely with mobile app/website when the AWC Thermostat controls are used.

With an iGate 2 communicating system, users and contractors have a web-enabled gateway to system information never before available and exclusive to ClimateMaster products.

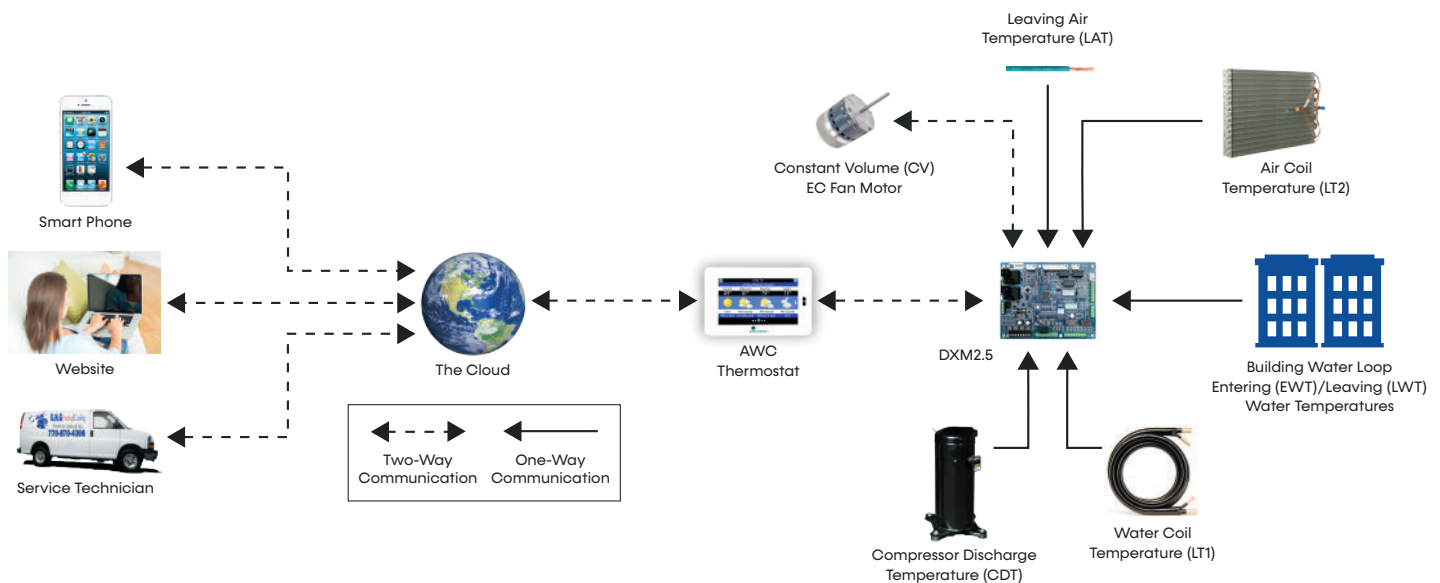

ClimateMaster works continually to improve its products. As a result, the design and specifications of each product at the time of order may be changed without notice and may not be as described herein. Please contact ClimateMaster's Customer Service Department at 800-299-9747 for specific information on the current design and specifications. Statements and other information contained herein are not express warranties and do not form the basis of any bargain between the parties, but are merely ClimateMaster's opinion or commendation of its products. The latest version of this document is available at www.climatemaster.com. Engineered and assembled in the USA. © ClimateMaster, Inc. All Rights Reserved 2024

iGate 2 Communicating (AWC) Thermostat

Models:
SC
006-060

iGATE 2 COMMUNICATION – CLOUD CONNECTED, WEB-ENABLED INFORMATION GATEWAY TO MONITOR, CONTROL, AND DIAGNOSE YOUR SYSTEM

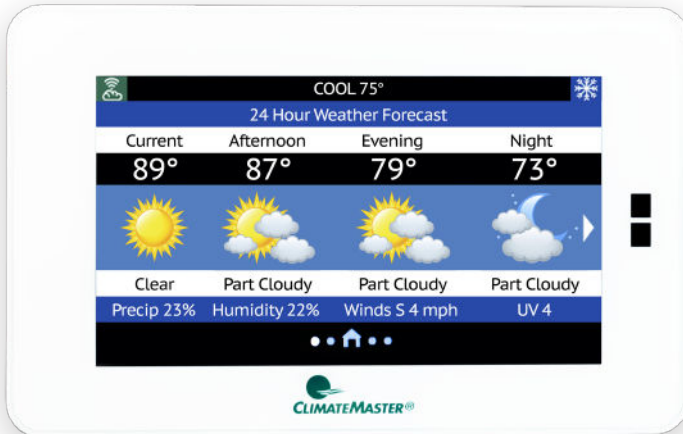

The iGate 2 Communicating (AWC) Thermostat is innovating the future of comfort technology, one building at a time. The inspired design of the touch screen interface allows you to see real-time data for the efficiency and health of your system, with early warnings for potential system faults. The cloud based information gateway allows technicians to remotely diagnose system issues before occupants even know there is a problem. Control and monitor the system in your home or business from anywhere in the world with an easy to use app on your phone.

Features with Efficiency in Mind



Touchscreen Interface

A brilliantly customizable touch screen monitor for simple control.



Seamless Integration

Between your AWC Thermostat and comfort system.



(Mobile) Remote System Control

Control temperature and schedule from anywhere in the world.



Early Fault Warnings

Alerts the building owner and the contractor of potential system faults in the future.



Remote Diagnostics

Enable the contractor to remotely diagnose system issues, adjust system settings, and reset faults.



Real-Time Operations Data and System Schematics

Access simply via the myUplink Pro Account and web portal to view system diagrams with current operating temperatures.



Revenue Stream

HVAC professionals can offer owners service contracts with remote monitoring and diagnostic capabilities without the large expense of a building management system.



ClimateMaster works continually to improve its products. As a result, the design and specifications of each product at the time of order may be changed without notice and may not be as described herein. Please contact ClimateMaster's Customer Service Department at 800-299-9747 for specific information on the current design and specifications. Statements and other information contained herein are not express warranties and do not form the basis of any bargain between the parties, but are merely ClimateMaster's opinion or commendation of its products. The latest version of this document is available at www.climatemaster.com. Engineered and assembled in the USA. © ClimateMaster, Inc. All Rights Reserved 2024

HVAC Professional | User Experience

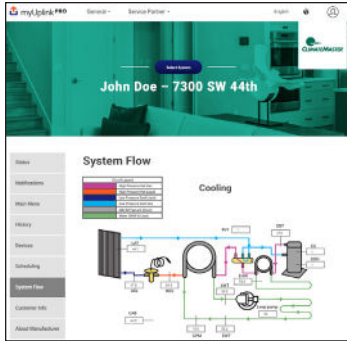

iGate 2 establishes a two-way link between the AWC Thermostat and the cloud, adding significant value for both residential and commercial customers. Our new thermostat works with your customers' Tranquility comfort systems to

provide the most efficient link between their system and your services. The customizable monitoring from the myUplink PRO web portal or phone app account allows for continuous system monitoring, analysis, repair recognition, and early warnings for potential system faults that are sent to you and your customer.



Benefits

- Remote login from anywhere, anytime from any internet connected device
- View system fault history with possible root causes
- Information is available for contractors to troubleshoot and diagnose systems remotely
- Secure internet connection keeps homeowner information private
- Access thermostat(s) through Android and iPhone mobile apps

Homeowner | User Experience

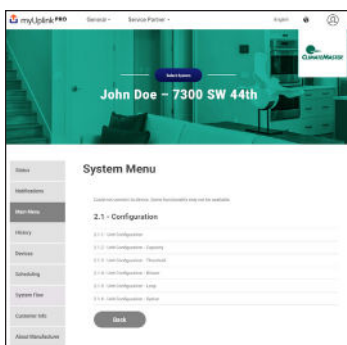

iGate 2 advanced unit controls enable a two-way communication link for critical system information between the unit and the cloud. From any internet connected device or smart phone, building owners can control and monitor their systems

from anywhere in the world. iGate 2 offers building owners peace of mind their systems are operating at peak performance with advanced operational performance issue notifications. HVAC professionals get notifications when systems are operating out of range. They can log in remotely to check system faults, review current operating conditions, and diagnose issues remotely. This gives the HVAC technician the upper hand when showing up to perform service, saving time which in turn, saves money.



Benefits

- Communicates personal settings and reminders through the iGate 2 communication system
- Easy-to-use, full-color, high-resolution user interface
- Sleek, intuitive control panel
- Secure internet connection keeps your information private
- Contains unit model, serial number and your HVAC professionals contact information
- System monitoring automatically contacts HVAC system providers when service is needed

Reference Calculations

Heating	Cooling
$LWT = EWT - \frac{HE}{GPM \times \text{Constant}}$	$LWT = EWT + \frac{HR}{GPM \times \text{Constant}} \quad LC = TC - SC$
$LAT = EAT + \frac{HC}{CFM \times 1.08}$	$LAT (DB) = EAT (DB) - \frac{SC}{CFM \times 1.08} \quad S/T = \frac{SC}{TC}$

Constant = 500 for water, 485 for antifreeze

Conversion Table - to convert inch-pound (English) to S-I (Metric)

Airflow	Water Flow	External Static Pressure	Water Pressure Drop
Airflow (L/s) = CFM x 0.472	Water Flow (L/s) = GPM x 0.0631	ESP (Pa) = ESP (in of wg) x 249	PD (kPa) = PD (ft of hd) x 2.99

Legend and Glossary of Abbreviations

Abbreviations	Descriptions
Btuh	Btu (British Thermal Unit) per hour
BMS	Building Management System
CDT	Compressor discharge temperature
CFM	Airflow, cubic feet per minute
COP	Coefficient of performance = Btuh output/Btuh input
CT EC	Electronically commutated constant torque blower motor
CV EC	Electronically commutated constant volume blower motor
DB	Dry bulb temperature, °F
DT	Delta T
EAT	Entering air temperature
EER	Energy efficient ratio = Btuh output/Watt input
ESP	External static pressure, inches w.g.
EWT	Entering water temperature
FPT	Female pipe thread
GPM	Water flow in U.S., gallons per minute
HC	Air heating capacity, Btuh
HE	Total heat of extraction, Btuh
HGRH	Hot Gas Reheat

Abbreviations	Descriptions
HR	Total heat of rejection, Btuh
HWG	Hot water generator (desuperheater) capacity, MBtuh
kW	Total power unit input, kilowatts
LAT	Leaving air temperature, °F
LC	Latent cooling capacity, Btuh
LOC	Loss of charge
LWT	Leaving water temperature, °F
MBtuh	1,000 Btu per hour
MPT	Male pipe thread
MWV	Motorized water valve
PSC	Permanent split capacitor
RDS	Refrigerant Detection System
SC	Sensible cooling capacity, Btuh
S/T	Sensible to total cooling ratio
TC	Total cooling capacity, Btuh
TD or delta T	Temperature differential
VFD	Variable frequency drive
WB	Wet bulb temperature, °F
WPD	Waterside pressure drop, psi or feet of head
WSE	Waterside economizer

ClimateMaster works continually to improve its products. As a result, the design and specifications of each product at the time of order may be changed without notice and may not be as described herein. Please contact ClimateMaster's Customer Service Department at 800-299-9747 for specific information on the current design and specifications. Statements and other information contained herein are not express warranties and do not form the basis of any bargain between the parties, but are merely ClimateMaster's opinion or commendation of its products. The latest version of this document is available at www.climatemaster.com. Engineered and assembled in the USA. © ClimateMaster, Inc. All Rights Reserved 2024

USE THE FOLLOWING SELECTION STEPS

- Determine the actual heating and cooling loads at the desired dry bulb and wet bulb conditions.
- Obtain the following design parameters: Entering water temperature, water flow rate in GPM, airflow in CFM, water flow pressure drop and design wet and dry bulb temperatures. Airflow CFM should be between 300 and 450 CFM per ton. Unit water pressure drop should be kept as close as possible to each other to make water balancing easier. Go to the appropriate tables and find the proper indicated water flow and water temperature.
- Select a unit based on total and sensible cooling conditions. Select a unit which is closest to, but no larger than, the actual cooling load.
- Enter tables at the design water flow and water temperature. Read the total and sensible cooling capacities. **NOTE: interpolation is permissible, extrapolation is not.**
- Read the heating capacity. If it exceeds the design criteria it is acceptable. It is quite normal for water-source heat pumps to be selected on cooling capacity only since the heating output is usually greater than the cooling capacity.
- Determine the correction factors associated with the variable factors of dry bulb and wet bulb.

Corrected Total Cooling =
tabulated total cooling x wet bulb correction.

Corrected Sensible Cooling =
tabulated sensible cooling x wet/dry bulb correction.
- Compare the corrected capacities to the load requirements. Normally if the capacities are within 10% of the loads, the equipment is acceptable. It is better to undersize than oversize, as undersizing improves humidity control, reduces sound levels and extends the life of the equipment.
- When completed, calculate water temperature rise and assess the selection. If the units selected are not within 10% of the load calculations, then review what effect changing the GPM, water temperature and/or air flow and air temperature would have on the corrected capacities. If the desired capacity cannot be achieved, select the next larger or smaller unit and repeat the procedure. Remember, when in doubt, undersize slightly for best performance.

EXAMPLE EQUIPMENT SELECTION FOR COOLING

Step 1: Load Determination

Assume we have determined that the appropriate cooling load at the desired dry bulb 80°F and wet bulb 65°F conditions is as follows:

Total Cooling 23,700 Btuh
Sensible Cooling 16,500 Btuh
Entering Air Temp..... 80°F Dry Bulb / 65°F Wet Bulb

Step 2: Design Conditions

Similarly, we have also obtained the following design parameters:

Entering Water Temp 90°F
Water Flow (Based upon 10°F rise in temp) .6.0 GPM
Airflow 800 CFM

Steps 3, 4 & 5: HP Selection

After making our preliminary selection (SC024), we enter the tables at design water flow and water temperature and read Total Cooling, Sensible Cooling and Heat of Rejection capacities:

Total Cooling 23,400 Btuh
Sensible Cooling 17,500 Btuh
Heat of Rejection 30,200 Btuh

Steps 6 and 7: Entering Airflow Corrections

Next, we determine our correction factors.

Corrected Values	Table	Ent Air	Airflow	Corrected
Corrected Total Cooling	= 23,400	x 0.9681	x 1.0050	= 22,767
Corrected Sensible Cooling	= 17,500	x 1.1213	x 0.9820	= 19,270
Corrected Heat of Rejection	= 30,200	x 0.9747	x 1.0434	= 30,713

Step 8: Water Temperature Rise Calculation and Assessment

Actual Temperature Rise 10.2°F

When we compare the Corrected Total Cooling and Corrected Sensible Cooling figures with our load requirements stated in Step 1, we discover that our selection is within ± 10% of our sensible load requirement. Furthermore, we see that our Corrected Total Cooling figure is within 1,000 Btuh the actual indicated load.

ClimateMaster works continually to improve its products. As a result, the design and specifications of each product at the time of order may be changed without notice and may not be as described herein. Please contact ClimateMaster's Customer Service Department at 800-299-9747 for specific information on the current design and specifications. Statements and other information contained herein are not express warranties and do not form the basis of any bargain between the parties, but are merely ClimateMaster's opinion or commendation of its products. The latest version of this document is available at www.climatemaster.com. Engineered and assembled in the USA. © ClimateMaster, Inc. All Rights Reserved 2024

Model Nomenclature

Models:
SC
006-060

1 | 2 | 3 | 4 | 5 | 6 | 7 | 8 | 9 | 10 | 11 | 12 | 13 | 14 | 15
| S | C | L | O | 2 | 4 | A | G | C | 3 | 0 | C | 0 | P | S |

MODEL

S = R-454B Refrigerant

MODEL TYPE

C = Compact Single-Stage Series

SUPPLY & RETURN CONFIGURATIONS

Horizontal Configuration

	Left	Right
Straight	L	R
Back	B	P

Vertical Configuration

	Left	Right
Top	T	K
Front/Top	F	

SIZE

006	018	041
009	024	042
012	030	048
015	036	060

REVISION

A = Current

VOLTAGE

G = 208/230-1-60	J = 208/230-1-60 Refrigerant Detection System
H = 208/230-3-60	K = 208/230-3-60 Refrigerant Detection System
E = 265-1-60	D = 265-1-60 Refrigerant Detection System
F = 460-3-60	L = 460-3-60 Refrigerant Detection System
N = 575-3-60	M = 575-3-60 Refrigerant Detection System

CONTROLS

Control	Standard	MPC
CXM2	C	N
DXM2.5	D	P
CXM2 with Disconnect	W	R
DXM2.5 with Disconnect	B	S

CABINET

Cabinet	UltraQuiet	Rail		Frame	
		1"	2"	1"	2"
Extended Range	No	1	J	K	A
	Yes	2	L	M	C
Standard Range	No	3	N	P	E
	Yes	4	F	S	G

STANDARD

S = Standard

BLOWER MOTOR

P = Permanent Split Capacitor (PSC)
 T = Constant Torque Electronically Commuted (CT EC)
 V = Constant Volume Electronically Commuted (CV EC)

EXTENDED OPTIONS

0 = Standard
 C = Cooling Only

DRAIN PAN/HEAT EXCHANGER OPTIONS

C = Standard Drain Pan, Non-Coated Air Coil
 T = Standard Drain Pan, Tin-Coated Air Coil
 S = Stainless Steel Drain Pan, Non-Coated Air Coil
 R = Stainless Steel Drain Pan, Tin-Coated Air Coil

WATER/HEAT EXCHANGER OPTIONS

Water Option	Standard	Cupro Nickel
None	0	Z

Use ClimateMaster's selection software at <https://climatemastersolutions.com/eRep/> to configure your Tranquility SC model.

Performance Data: ASHRAE/AHRI/ISO 13256-1

Models:
SC
006-060

ASHRAE/AHRI/ISO 13256-1 English (I-P) Units

Model	Motor Type	Water Loop Heat Pump				Ground Water Heat Pump				Ground Loop Heat Pump			
		Cooling 86°F		Heating 68°F		Cooling 59°F		Heating 50°F		Full Cooling 77°F		Full Heating 32°F	
		Capacity Btuh	EER Btuh/W	Capacity Btuh	COP	Capacity Btuh	EER Btuh/W	Capacity Btuh	COP	Capacity Btuh	EER Btuh/W	Capacity Btuh	COP
SC006	PSC	5,900	13.4	8,400	4.8	7,200	22.8	6,600	3.9	6,300	15.5	4,900	3.1
	EC	6,100	15.0	8,300	5.1	7,300	26.6	6,500	4.0	6,400	17.7	4,800	3.3
SC009	PSC	8,500	13.8	11,700	4.4	10,000	22.0	9,500	3.9	8,900	15.7	7,200	3.3
	EC	8,600	14.3	11,600	4.5	10,000	23.4	9,500	4.0	9,000	16.7	7,200	3.3
SC012	PSC	10,500	12.7	14,400	4.5	12,800	19.0	11,700	3.9	11,400	14.1	9,300	3.2
	EC	10,700	13.4	14,400	4.6	13,000	21.0	11,700	4.0	11,500	14.9	9,300	3.3
SC015	PSC	14,500	15.2	16,000	4.8	16,700	23.5	13,800	4.3	15,000	16.5	11,000	3.5
	EC	14,700	16.4	15,900	4.9	16,900	26.2	13,800	4.5	15,200	17.3	10,700	3.6
SC018	PSC	17,900	14.3	21,500	4.9	20,700	23.0	17,900	4.2	19,000	16.1	14,000	3.4
	EC	18,000	15.0	21,500	5.1	20,900	25.0	17,700	4.4	19,400	17.3	13,800	3.6
SC024	PSC	24,700	14.7	28,800	5.0	27,500	23.3	24,200	4.4	25,600	17.3	19,000	3.6
	EC	24,900	15.4	28,500	5.1	27,800	24.0	24,000	4.5	25,800	18.0	19,000	3.7
SC030	PSC	28,800	13.7	35,400	4.6	32,400	21.0	29,200	4.1	30,100	16.0	23,300	3.5
	EC	29,200	14.5	35,000	4.8	32,800	23.5	28,800	4.3	30,500	17.3	23,000	3.6
SC036	PSC	34,800	14.6	43,900	4.6	38,800	23.3	36,200	4.0	36,100	16.7	28,500	3.4
	EC	35,200	15.3	43,500	4.8	39,200	25.2	35,800	4.2	36,400	17.4	27,900	3.6
SC042	PSC	41,100	14.0	49,500	4.6	45,200	21.0	40,900	4.0	42,700	16.0	32,700	3.4
	EC	41,800	15.2	48,500	4.9	46,000	22.9	39,900	4.3	43,400	17.4	31,700	3.5
SC048	PSC	48,000	14.3	57,900	4.7	53,000	21.5	48,000	4.1	50,400	16.5	38,000	3.5
	EC	48,900	15.2	57,500	4.8	53,500	22.8	47,700	4.2	50,800	17.6	38,100	3.5
SC060	PSC	59,400	13.2	70,000	4.4	65,800	18.2	59,200	3.9	61,300	15.0	45,400	3.3
	EC	60,200	14.7	68,000	4.7	67,000	21.5	57,100	4.2	62,200	17.4	44,300	3.5
SC041	PSC	36,000	14.0	43,300	4.3	40,300	22.0	35,500	3.8	37,500	16.5	28,000	3.3

Notes:

- Where dual voltages are available, ratings are based on the lower voltage setting.
- Cooling capacities based upon 80.6°F DB, 66.2°F WB entering air temperature.
- Heating capacities based upon 68°F DB, 59°F WB entering air temperature.
- Ground Loop Heat Pump ratings based on 15% antifreeze solution.

Performance Data: ASHRAE/AHRI/ISO 13256-1

Models:
SC
006-060

ASHRAE/AHRI/ISO 13256-1 Metric (S-I) Units

Model	Motor Type	Water Loop Heat Pump				Ground Water Heat Pump				Ground Loop Heat Pump			
		Cooling 30°C		Heating 20°C		Cooling 15°C		Heating 10°C		Full Cooling 25°C		Full Heating 0°C	
		Capacity kW	EER W/W	Capacity kW	COP	Capacity kW	EER W/W	Capacity kW	COP	Capacity kW	EER W/W	Capacity kW	COP
SC006	PSC	2	3.9	2	4.8	2	6.7	2	3.9	2	4.5	1	3.1
	EC	2	4.4	2	5.1	2	7.8	2	4.0	2	5.2	1	3.3
SC009	PSC	2	4.0	3	4.4	3	6.5	3	3.9	3	4.6	2	3.3
	EC	3	4.2	3	4.5	3	6.9	3	4.0	3	4.9	2	3.3
SC012	PSC	3	3.7	4.2	4.5	3.8	5.6	3	3.9	3	4.1	3	3.2
	EC	3	3.9	4.2	4.6	3.8	6.2	3	4.0	3	4.4	3	3.3
SC015	PSC	4	4.5	4.7	4.8	4.9	6.9	4	4.3	4	4.8	3	3.5
	EC	4	4.8	4.7	4.9	5.0	7.7	4	4.5	4	5.1	3	3.6
SC018	PSC	5	4.2	6.3	4.9	6.1	6.7	5	4.2	6	4.7	4	3.4
	EC	5	4.4	6.3	5.1	6.1	7.3	5	4.4	6	5.1	4	3.6
SC024	PSC	7.2	4.3	8.4	5.0	8.1	6.8	7.1	4.4	7.5	5.1	5.6	3.6
	EC	7.3	4.5	8.4	5.1	8.1	7.0	7.0	4.5	7.6	5.3	5.6	3.7
SC030	PSC	8.4	4.0	10.4	4.6	9.5	6.2	8.6	4.1	8.8	4.7	6.8	3.5
	EC	8.6	4.3	10.3	4.8	9.6	6.9	8.4	4.3	8.9	5.1	6.7	3.6
SC036	PSC	10.2	4.3	12.9	4.6	11.4	6.8	10.6	4.0	10.6	4.9	8.4	3.4
	EC	10.3	4.5	12.7	4.8	11.5	7.4	10.5	4.2	10.7	5.1	8.2	3.6
SC042	PSC	12.0	4.1	14.5	4.6	13.2	6.2	12.0	4.0	12.5	4.7	9.6	3.4
	EC	12.3	4.5	14.2	4.9	13.5	6.7	11.7	4.3	12.7	5.1	9.3	3.5
SC048	PSC	14.1	4.2	17.0	4.7	15.5	6.3	14.1	4.1	14.8	4.8	11.1	3.5
	EC	14.3	4.5	16.9	4.8	15.7	6.7	14.0	4.2	14.9	5.2	11.2	3.5
SC060	PSC	17.4	3.9	20.5	4.4	19.3	5.3	17.3	3.9	18.0	4.4	13.3	3.3
	EC	17.6	4.3	19.9	4.7	19.6	6.3	16.7	4.2	18.2	5.1	13.0	3.5
SC041	PSC	10.6	4.1	12.7	4.3	11.8	6.5	10.4	3.8	11.0	4.8	8.2	3.3

Notes:

- Where dual voltages are available, ratings are based on the lower voltage setting.
- Cooling capacities based upon 27°C DB, 19°C WB entering air temperature.
- Heating capacities based upon 20°C DB, 15°C WB entering air temperature.
- Ground Loop Heat Pump ratings based on 15% antifreeze solution.

Performance Data: Selection Notes

Models:
SC
006-060

For operation in the shaded area when water is used instead of an antifreeze solution, the LWT (Leaving Water Temperature) must be calculated. Flow must be maintained to a level such that the LWT is maintained above 40°F (4.4°C) when the JW3 jumper is not clipped (see example below). Otherwise, appropriate levels of a proper antifreeze solution should be used in systems with leaving water temperatures of 40°F (4.4°C) or below and the JW3 jumper should be clipped. This is due to the potential of the refrigerant temperature being as low as 32°F (0°C) with 40°F (4.4°C) LWT, which may lead to a nuisance cutout due to the activation of the Low Temperature Protection. JW3 should never be clipped for standard-range equipment or systems without antifreeze.

Example:

At 50°F EWT (Entering Water Temperature) and 1.5 GPM/ton, a 3-ton unit has a HE of 22,500 Btuh. To calculate LWT, rearrange the formula for HE as follows:

$HE = TD \times GPM \times 500$, where HE = Heat of Extraction (Btuh); TD = temperature difference (EWT - LWT) and GPM = U.S. Gallons per Minute.

$$TD = HE / (GPM \times 500)$$

$$TD = 22,500 / (1.5 \times 500)$$

$$TD = 10^\circ F$$

$$LWT = EWT - TD$$

$$LWT = 50 - 10 = 40^\circ F$$

In this example, as long as the EWT does not fall below 50°F, the system will operate as designed. For EWTs below 50°F, higher flow rates will be required (open loop systems, for example, require at least 2 GPM/ton when EWT is below 50°F).

		Heating - EAT 70°F				
	EER	HC	Power kW	HE	LAT	COP
Not Recommended						
		4.0	0.45	2.5	84.6	2.6
8.6	27.4	4.6	0.46	3.0	86.8	2.9
8.6	31.0	4.8	0.47	3.2	87.8	3.0
8.6	33.0	4.9	0.47	3.3	88.3	3.1
8.4	23.3	5.4	0.48	3.8	90.2	3.3
8.5	26.3	5.7	0.49	4.0	91.4	3.4
8.6	27.9	5.9	0.49	4.2	92.1	3.5
8.2	19.8	6.2	0.50	4.5	93.6	3.7
4	22.3	6.6	0.50	4.9	95.0	3.8
	23.7	6.8	0.51	5.0	95.8	3.9
	16.7	7.0	0.51	5.3	96.9	4.0
	18.8	7.4	0.52	5.6	98.5	4.1
		7.6	0.52	5.8	99.3	4.2
			0.53	6.0	100.0	4.3

ClimateMaster works continually to improve its products. As a result, the design and specifications of each product at the time of order may be changed without notice and may not be as described herein. Please contact ClimateMaster's Customer Service Department at 800-299-9747 for specific information on the current design and specifications. Statements and other information contained herein are not express warranties and do not form the basis of any bargain between the parties, but are merely ClimateMaster's opinion or commendation of its products. The latest version of this document is available at www.climate-master.com. Engineered and assembled in the USA. © ClimateMaster, Inc. All Rights Reserved 2024

Performance Data SC*006 (PSC Blower Motor)

Models:
SC
006-060

275 CFM Rated Airflow

EWT °F	WPD			COOLING - EAT 80/67°F					WPD			Heating - EAT 70°F			
	FLOW GPM	PSI	FT	TC	SC	kW	HR	EER	FLOW GPM	PSI	FT	HC	kW	COP	HE
20	Operation Not Recommended								2.0	4.4	10.1	4.4	0.5	2.8	2.8
30	1.0	1.5	3.6	7.5	5.5	0.3	8.4	29.5	1.0	1.5	3.6	4.9	0.5	3.0	3.2
	1.5	2.7	6.1	7.5	5.4	0.2	8.3	31.9	1.5	2.7	6.1	5.0	0.5	3.1	3.4
	2.0	3.8	8.7	7.5	5.3	0.2	8.2	33.2	2.0	3.8	8.7	5.1	0.5	3.1	3.5
40	1.0	1.3	3.0	7.4	5.6	0.3	8.4	25.5	1.0	1.3	3.0	5.6	0.5	3.4	3.9
	1.5	2.3	5.3	7.5	5.6	0.3	8.4	27.7	1.5	2.3	5.3	5.8	0.5	3.5	4.2
	2.0	3.3	7.6	7.5	5.5	0.3	8.4	28.8	2.0	3.3	7.6	6.0	0.5	3.5	4.3
50	1.0	1.1	2.6	7.2	5.5	0.3	8.3	21.9	1.0	1.1	2.6	6.5	0.5	3.8	4.8
	1.5	2.0	4.7	7.3	5.6	0.3	8.4	23.9	1.5	2.0	4.7	6.8	0.5	3.9	5.0
	2.0	2.9	6.7	7.4	5.6	0.3	8.4	24.9	2.0	2.9	6.7	6.9	0.5	4.0	5.2
60	1.0	1.0	2.4	6.8	5.4	0.4	8.1	18.6	1.0	1.0	2.4	7.4	0.5	4.2	5.6
	1.5	1.8	4.2	7.0	5.5	0.3	8.2	20.4	1.5	1.8	4.2	7.7	0.5	4.4	6.0
	2.0	2.6	6.1	7.1	5.5	0.3	8.3	21.3	2.0	2.6	6.1	7.9	0.5	4.5	6.2
70	1.0	1.0	2.2	6.4	5.1	0.4	7.8	15.7	1.0	1.0	2.2	8.3	0.5	4.7	6.5
	1.5	1.7	3.9	6.7	5.3	0.4	8.0	17.2	1.5	1.7	3.9	8.7	0.5	4.9	6.9
	2.0	2.4	5.6	6.8	5.3	0.4	8.1	18.1	2.0	2.4	5.6	8.9	0.5	5.0	7.1
80	1.0	0.9	2.1	6.0	4.8	0.5	7.5	13.1	1.0	0.9	2.1	9.2	0.5	5.1	7.4
	1.5	1.6	3.7	6.2	5.0	0.4	7.7	14.4	1.5	1.6	3.7	9.6	0.5	5.3	7.8
	2.0	2.3	5.3	6.3	5.1	0.4	7.8	15.1	2.0	2.3	5.3	9.9	0.5	5.4	8.0
90	1.0	0.9	2.1	5.5	4.5	0.5	7.2	10.7	1.0	0.9	2.1	10.0	0.5	5.5	8.2
	1.5	1.6	3.6	5.7	4.7	0.5	7.4	11.9	1.5	1.6	3.6	10.4	0.5	5.7	8.6
	2.0	2.2	5.1	5.9	4.8	0.5	7.5	12.5	2.0	2.2	5.1	10.7	0.5	5.8	8.8
100	1.0	0.9	2.1	5.0	4.2	0.6	7.0	8.7	Operation Not Recommended						
	1.5	1.5	3.5	5.2	4.4	0.5	7.1	9.6							
	2.0	2.1	5.0	5.4	4.4	0.5	7.2	10.1							
110	1.0	0.9	2.0	4.5	3.9	0.6	6.7	7.0							
	1.5	1.5	3.4	4.7	4.1	0.6	6.8	7.8							
	2.0	2.1	4.8	4.8	4.1	0.6	6.9	8.2							
120	1.0	0.8	1.9	4.0	3.7	0.7	6.5	5.6							
	1.5	1.4	3.3	4.2	3.8	0.7	6.6	6.2							
	2.0	2.0	4.7	4.3	3.8	0.7	6.6	6.5							

Notes:

- Interpolation is permissible; extrapolation is not.
- All entering air conditions are 80°F (26.6°C) DB and 67°F (19.4°C) WB in cooling, and 70°F (21°C) DB in heating.
- Table does not reflect fan or pump power corrections for AHRI/ISO conditions.
- All performance is based upon the lower voltage of dual voltage rated units.
- Performance stated is at the rated power supply; performance may vary as the power supply varies from the rated.
- Operation below 40°F (4.4°C) is based upon 20% methanol antifreeze solution.
- Operation below 60°F (15.5°C) EWT requires optional insulated water/refrigerant circuit.
- See performance correction tables for operating conditions other than those listed above.
- See Performance Data Selection Notes for operation in the shaded areas.
- Performance capacities shown in thousands of Btu/h.
- For unit operation in the shaded area when LWT is below 40°F (4.4°C), antifreeze must be used and the JW3 jumper on the DXM2.5/CXM2 should be clipped. This is due to the potential of the refrigerant temperature being as low as 32°F (0°C) with 40°F (4.4°C) LWT, which may lead to a nuisance cutout due to the activation of the Low Temperature Protection. JW3 should never be clipped for standard range equipment or systems without antifreeze.

Performance Data SC*006 (EC Blower Motor)

Models:
SC
006-060

275 CFM Rated Airflow

EWT °F	WPD			COOLING - EAT 80/67°F					WPD			Heating - EAT 70°F			
	FLOW GPM	PSI	FT	TC	SC	kW	HR	EER	FLOW GPM	PSI	FT	HC	kW	COP	HE
20	Operation Not Recommended								2.0	4.4	10.1	4.4	0.4	2.8	2.8
30	1.0	1.5	3.6	7.6	5.5	0.2	8.4	31.7	1.0	1.5	3.6	4.8	0.5	3.1	3.2
	1.5	2.7	6.1	7.6	5.4	0.2	8.3	34.5	1.5	2.7	6.1	5.0	0.5	3.1	3.4
	2.0	3.8	8.7	7.5	5.4	0.2	8.2	36.0	2.0	3.8	8.7	5.0	0.5	3.2	3.5
40	1.0	1.3	3.0	7.5	5.6	0.3	8.4	27.2	1.0	1.3	3.0	5.6	0.5	3.4	3.9
	1.5	2.3	5.3	7.5	5.6	0.3	8.4	29.6	1.5	2.3	5.3	5.8	0.5	3.6	4.2
	2.0	3.3	7.6	7.6	5.6	0.2	8.4	30.9	2.0	3.3	7.6	5.9	0.5	3.6	4.3
50	1.0	1.1	2.6	7.2	5.6	0.3	8.3	23.2	1.0	1.1	2.6	6.4	0.5	3.9	4.8
	1.5	2.0	4.7	7.4	5.6	0.3	8.4	25.4	1.5	2.0	4.7	6.7	0.5	4.0	5.0
	2.0	2.9	6.7	7.4	5.6	0.3	8.4	26.5	2.0	2.9	6.7	6.9	0.5	4.1	5.2
60	1.0	1.0	2.4	6.9	5.4	0.4	8.1	19.7	1.0	1.0	2.4	7.3	0.5	4.3	5.6
	1.5	1.8	4.2	7.1	5.5	0.3	8.2	21.5	1.5	1.8	4.2	7.7	0.5	4.5	6.0
	2.0	2.6	6.1	7.2	5.5	0.3	8.3	22.6	2.0	2.6	6.1	7.9	0.5	4.6	6.2
70	1.0	1.0	2.2	6.5	5.2	0.4	7.8	16.5	1.0	1.0	2.2	8.2	0.5	4.8	6.5
	1.5	1.7	3.9	6.7	5.3	0.4	8.0	18.1	1.5	1.7	3.9	8.7	0.5	5.0	6.9
	2.0	2.4	5.6	6.8	5.4	0.4	8.1	19.0	2.0	2.4	5.6	8.9	0.5	5.1	7.1
80	1.0	0.9	2.1	6.0	4.9	0.4	7.5	13.7	1.0	0.9	2.1	9.1	0.5	5.2	7.4
	1.5	1.6	3.7	6.3	5.0	0.4	7.7	15.1	1.5	1.6	3.7	9.6	0.5	5.4	7.8
	2.0	2.3	5.3	6.4	5.1	0.4	7.8	15.8	2.0	2.3	5.3	9.8	0.5	5.5	8.0
90	1.0	0.9	2.1	5.6	4.6	0.5	7.2	11.2	1.0	0.9	2.1	10.0	0.5	5.6	8.2
	1.5	1.6	3.6	5.8	4.7	0.5	7.4	12.4	1.5	1.6	3.6	10.4	0.5	5.8	8.6
	2.0	2.2	5.1	5.9	4.8	0.5	7.5	13.0	2.0	2.2	5.1	10.6	0.5	5.9	8.8
100	1.0	0.9	2.1	5.1	4.3	0.6	7.0	9.1	Operation Not Recommended						
	1.5	1.5	3.5	5.3	4.4	0.5	7.1	10.0							
	2.0	2.1	5.0	5.4	4.5	0.5	7.2	10.6							
110	1.0	0.9	2.0	4.6	4.0	0.6	6.7	7.3							
	1.5	1.5	3.4	4.8	4.1	0.6	6.8	8.1							
	2.0	2.1	4.8	4.9	4.2	0.6	6.9	8.5							
120	1.0	0.8	1.9	4.1	3.7	0.7	6.5	5.8							
	1.5	1.4	3.3	4.3	3.8	0.7	6.6	6.4							
	2.0	2.0	4.7	4.4	3.9	0.7	6.6	6.7							

Notes:

- Interpolation is permissible; extrapolation is not.
- All entering air conditions are 80°F (26.6°C) DB and 67°F (19.4°C) WB in cooling, and 70°F (21°C) DB in heating.
- Table does not reflect fan or pump power corrections for AHRI/ISO conditions.
- All performance is based upon the lower voltage of dual voltage rated units.
- Performance stated is at the rated power supply; performance may vary as the power supply varies from the rated.
- Operation below 40°F (4.4°C) is based upon 20% methanol antifreeze solution.
- Operation below 60°F (15.5°C) EWT requires optional insulated water/refrigerant circuit.
- See performance correction tables for operating conditions other than those listed above.
- See Performance Data Selection Notes for operation in the shaded areas.
- Performance capacities shown in thousands of Btu/h.
- For unit operation in the shaded area when LWT is below 40°F (4.4°C), antifreeze must be used and the JW3 jumper on the DXM2.5/CXM2 should be clipped. This is due to the potential of the refrigerant temperature being as low as 32°F (0°C) with 40°F (4.4°C) LWT, which may lead to a nuisance cutout due to the activation of the Low Temperature Protection. JW3 should never be clipped for standard range equipment or systems without antifreeze.

Performance Data SC*009 (PSC Blower Motor)

Models:
SC
006-060

345 CFM Rated Airflow

EWT °F	WPD			COOLING - EAT 80/67°F					WPD			Heating - EAT 70°F			
	FLOW GPM	PSI	FT	TC	SC	kW	HR	EER	FLOW GPM	PSI	FT	HC	kW	COP	HE
20	Operation Not Recommended								2.5	6.3	14.5	6.2	0.7	2.7	3.9
30	1.3	1.9	4.4	10.6	7.6	0.4	11.9	28.7	1.3	1.9	4.4	6.9	0.7	3.0	4.6
	1.9	3.5	8.0	10.7	7.6	0.3	11.8	31.8	1.9	3.5	8.0	7.2	0.7	3.1	4.9
	2.5	5.0	11.6	10.7	7.6	0.3	11.8	33.5	2.5	5.0	11.6	7.4	0.7	3.1	5.0
40	1.3	1.6	3.6	10.4	7.5	0.4	11.8	24.2	1.3	1.6	3.6	8.1	0.7	3.3	5.7
	1.9	2.9	6.6	10.5	7.5	0.4	11.9	26.9	1.9	2.9	6.6	8.5	0.7	3.5	6.0
	2.5	4.2	9.6	10.6	7.6	0.4	11.9	28.4	2.5	4.2	9.6	8.7	0.7	3.5	6.2
50	1.3	1.4	3.2	10.0	7.3	0.5	11.6	20.5	1.3	1.4	3.2	9.3	0.7	3.7	6.8
	1.9	2.5	5.7	10.2	7.4	0.4	11.8	22.8	1.9	2.5	5.7	9.7	0.7	3.8	7.2
	2.5	3.6	8.3	10.3	7.5	0.4	11.8	24.0	2.5	3.6	8.3	10.0	0.7	3.9	7.4
60	1.3	1.3	2.9	9.5	7.1	0.5	11.4	17.3	1.3	1.3	2.9	10.5	0.8	4.0	7.9
	1.9	2.3	5.2	9.8	7.2	0.5	11.6	19.2	1.9	2.3	5.2	11.0	0.8	4.2	8.4
	2.5	3.3	7.6	10.0	7.3	0.5	11.6	20.3	2.5	3.3	7.6	11.3	0.8	4.3	8.7
70	1.3	1.2	2.8	9.0	6.8	0.6	11.1	14.6	1.3	1.2	2.8	11.7	0.8	4.4	9.0
	1.9	2.2	5.0	9.3	7.0	0.6	11.3	16.2	1.9	2.2	5.0	12.3	0.8	4.5	9.6
	2.5	3.1	7.2	9.5	7.0	0.6	11.4	17.0	2.5	3.1	7.2	12.6	0.8	4.6	9.9
80	1.3	1.2	2.8	8.4	6.5	0.7	10.7	12.3	1.3	1.2	2.8	12.8	0.8	4.7	10.1
	1.9	2.2	5.0	8.7	6.7	0.6	10.9	13.6	1.9	2.2	5.0	13.5	0.8	4.9	10.7
	2.5	3.1	7.2	8.9	6.8	0.6	11.0	14.3	2.5	3.1	7.2	13.8	0.8	4.9	11.0
90	1.3	1.2	2.8	7.8	6.3	0.8	10.3	10.3	1.3	1.2	2.8	13.9	0.8	5.0	11.1
	1.9	2.2	5.0	8.1	6.4	0.7	10.6	11.4	1.9	2.2	5.0	14.6	0.8	5.1	11.8
	2.5	3.1	7.2	8.3	6.5	0.7	10.7	12.0	2.5	3.1	7.2	15.0	0.8	5.2	12.1
100	1.3	1.2	2.8	7.1	6.0	0.8	10.0	8.6	Operation Not Recommended						
	1.9	2.1	5.0	7.5	6.1	0.8	10.2	9.5							
	2.5	3.1	7.2	7.7	6.2	0.8	10.3	10.0							
110	1.3	1.1	2.6	6.5	5.7	0.9	9.6	7.2							
	1.9	2.1	4.8	6.8	5.9	0.9	9.8	7.9							
	2.5	3.0	6.9	7.0	5.9	0.8	9.9	8.3							
120	1.3	1.0	2.4	5.9	5.4	1.0	9.2	6.0							
	1.9	1.9	4.3	6.2	5.6	0.9	9.4	6.6							
	2.5	2.7	6.3	6.4	5.6	0.9	9.5	6.9							

Notes:

- Interpolation is permissible; extrapolation is not.
- All entering air conditions are 80°F (26.6°C) DB and 67°F (19.4°C) WB in cooling, and 70°F (21°C) DB in heating.
- Table does not reflect fan or pump power corrections for AHRI/ISO conditions.
- All performance is based upon the lower voltage of dual voltage rated units.
- Performance stated is at the rated power supply; performance may vary as the power supply varies from the rated.
- Operation below 40°F (4.4°C) is based upon 20% methanol antifreeze solution.
- Operation below 60°F (15.5°C) EWT requires optional insulated water/refrigerant circuit.
- See performance correction tables for operating conditions other than those listed above.
- See Performance Data Selection Notes for operation in the shaded areas.
- Performance capacities shown in thousands of Btu/h.
- For unit operation in the shaded area when LWT is below 40°F (4.4°C), antifreeze must be used and the JW3 jumper on the DXM2.5/CXM2 should be clipped. This is due to the potential of the refrigerant temperature being as low as 32°F (0°C) with 40°F (4.4°C) LWT, which may lead to a nuisance cutout due to the activation of the Low Temperature Protection. JW3 should never be clipped for standard range equipment or systems without antifreeze.

Performance Data SC*009 (EC Blower Motor)

Models:
SC
006-060

345 CFM Rated Airflow

EWT °F	WPD			COOLING - EAT 80/67°F					WPD			Heating - EAT 70°F			
	FLOW GPM	PSI	FT	TC	SC	kW	HR	EER	FLOW GPM	PSI	FT	HC	kW	COP	HE
20	Operation Not Recommended								2.5	6.3	14.5	6.1	0.6	2.8	3.9
30	1.3	1.9	4.4	10.7	7.6	0.4	11.9	30.5	1.3	1.9	4.4	6.9	0.7	3.0	4.6
	1.9	3.5	8.0	10.8	7.7	0.3	11.8	34.1	1.9	3.5	8.0	7.2	0.7	3.1	4.9
	2.5	5.0	11.6	10.8	7.7	0.3	11.8	36.0	2.5	5.0	11.6	7.3	0.7	3.2	5.0
40	1.3	1.6	3.6	10.4	7.5	0.4	11.8	25.6	1.3	1.6	3.6	8.0	0.7	3.4	5.7
	1.9	2.9	6.6	10.6	7.6	0.4	11.9	28.6	1.9	2.9	6.6	8.4	0.7	3.5	6.0
	2.5	4.2	9.6	10.7	7.6	0.4	11.9	30.2	2.5	4.2	9.6	8.6	0.7	3.6	6.2
50	1.3	1.4	3.2	10.1	7.3	0.5	11.6	21.5	1.3	1.4	3.2	9.2	0.7	3.8	6.8
	1.9	2.5	5.7	10.3	7.4	0.4	11.8	24.0	1.9	2.5	5.7	9.7	0.7	3.9	7.2
	2.5	3.6	8.3	10.4	7.5	0.4	11.8	25.4	2.5	3.6	8.3	9.9	0.7	4.0	7.4
60	1.3	1.3	2.9	9.6	7.1	0.5	11.4	18.1	1.3	1.3	2.9	10.4	0.7	4.1	7.9
	1.9	2.3	5.2	9.9	7.3	0.5	11.6	20.1	1.9	2.3	5.2	10.9	0.7	4.3	8.4
	2.5	3.3	7.6	10.0	7.3	0.5	11.6	21.3	2.5	3.3	7.6	11.2	0.8	4.4	8.7
70	1.3	1.2	2.8	9.0	6.9	0.6	11.1	15.2	1.3	1.2	2.8	11.6	0.8	4.5	9.0
	1.9	2.2	5.0	9.4	7.0	0.6	11.3	16.9	1.9	2.2	5.0	12.2	0.8	4.6	9.6
	2.5	3.1	7.2	9.5	7.1	0.5	11.4	17.8	2.5	3.1	7.2	12.5	0.8	4.7	9.9
80	1.3	1.2	2.8	8.5	6.6	0.7	10.7	12.8	1.3	1.2	2.8	12.8	0.8	4.8	10.1
	1.9	2.2	5.0	8.8	6.8	0.6	10.9	14.1	1.9	2.2	5.0	13.4	0.8	5.0	10.7
	2.5	3.1	7.2	9.0	6.8	0.6	11.0	14.9	2.5	3.1	7.2	13.7	0.8	5.0	11.0
90	1.3	1.2	2.8	7.8	6.3	0.7	10.3	10.7	1.3	1.2	2.8	13.9	0.8	5.1	11.1
	1.9	2.2	5.0	8.2	6.5	0.7	10.6	11.8	1.9	2.2	5.0	14.5	0.8	5.2	11.8
	2.5	3.1	7.2	8.4	6.6	0.7	10.7	12.4	2.5	3.1	7.2	14.9	0.8	5.3	12.1
100	1.3	1.2	2.8	7.2	6.0	0.8	10.0	8.9	Operation Not Recommended						
	1.9	2.1	5.0	7.5	6.2	0.8	10.2	9.8							
	2.5	3.1	7.2	7.7	6.3	0.7	10.3	10.3							
110	1.3	1.1	2.6	6.6	5.8	0.9	9.6	7.4							
	1.9	2.1	4.8	6.9	5.9	0.8	9.8	8.2							
	2.5	3.0	6.9	7.1	6.0	0.8	9.9	8.6							
120	1.3	1.0	2.4	6.0	5.5	1.0	9.2	6.2							
	1.9	1.9	4.3	6.3	5.6	0.9	9.4	6.8							
	2.5	2.7	6.3	6.4	5.7	0.9	9.5	7.1							

Notes:

- Interpolation is permissible; extrapolation is not.
- All entering air conditions are 80°F (26.6°C) DB and 67°F (19.4°C) WB in cooling, and 70°F (21°C) DB in heating.
- Table does not reflect fan or pump power corrections for AHRI/ISO conditions.
- All performance is based upon the lower voltage of dual voltage rated units.
- Performance stated is at the rated power supply; performance may vary as the power supply varies from the rated.
- Operation below 40°F (4.4°C) is based upon 20% methanol antifreeze solution.
- Operation below 60°F (15.5°C) EWT requires optional insulated water/refrigerant circuit.
- See performance correction tables for operating conditions other than those listed above.
- See Performance Data Selection Notes for operation in the shaded areas.
- Performance capacities shown in thousands of Btu/h.
- For unit operation in the shaded area when LWT is below 40°F (4.4°C), antifreeze must be used and the JW3 jumper on the DXM2.5/CXM2 should be clipped. This is due to the potential of the refrigerant temperature being as low as 32°F (0°C) with 40°F (4.4°C) LWT, which may lead to a nuisance cutout due to the activation of the Low Temperature Protection. JW3 should never be clipped for standard range equipment or systems without antifreeze.

Performance Data SC*012 (PSC Blower Motor)

Models:
SC
006-060

400 CFM Rated Airflow

EWT °F	WPD			COOLING - EAT 80/67°F					WPD			Heating - EAT 70°F			
	FLOW GPM	PSI	FT	TC	SC	kW	HR	EER	FLOW GPM	PSI	FT	HC	kW	COP	HE
20	Operation Not Recommended								3.0	10.0	23.1	8.2	0.9	2.8	5.2
30	1.5	2.7	6.3	13.6	8.6	0.6	15.5	24.3	1.5	2.7	6.3	9.0	0.9	3.0	6.0
	2.3	5.6	13.0	13.8	8.7	0.5	15.5	27.0	2.3	5.6	13.0	9.4	0.9	3.1	6.4
	3.0	8.5	19.6	13.8	8.8	0.5	15.5	28.4	3.0	8.5	19.6	9.7	0.9	3.1	6.6
40	1.5	2.3	5.4	13.3	8.4	0.6	15.4	21.1	1.5	2.3	5.4	10.4	0.9	3.3	7.3
	2.3	4.8	11.1	13.5	8.5	0.6	15.5	23.3	2.3	4.8	11.1	10.9	0.9	3.4	7.8
	3.0	7.3	16.8	13.6	8.6	0.6	15.5	24.5	3.0	7.3	16.8	11.2	0.9	3.5	8.0
50	1.5	2.0	4.7	12.8	8.1	0.7	15.2	18.3	1.5	2.0	4.7	11.9	1.0	3.7	8.6
	2.3	4.2	9.7	13.2	8.3	0.7	15.4	20.1	2.3	4.2	9.7	12.5	1.0	3.8	9.2
	3.0	6.4	14.7	13.3	8.4	0.6	15.4	21.2	3.0	6.4	14.7	12.9	1.0	3.9	9.5
60	1.5	1.8	4.2	12.3	7.9	0.8	14.9	15.8	1.5	1.8	4.2	13.4	1.0	4.0	10.0
	2.3	3.8	8.7	12.7	8.1	0.7	15.1	17.4	2.3	3.8	8.7	14.1	1.0	4.1	10.7
	3.0	5.7	13.2	12.8	8.1	0.7	15.2	18.3	3.0	5.7	13.2	14.5	1.0	4.2	11.0
70	1.5	1.7	3.8	11.6	7.6	0.9	14.6	13.6	1.5	1.7	3.8	14.9	1.0	4.3	11.4
	2.3	3.4	8.0	12.1	7.8	0.8	14.8	15.0	2.3	3.4	8.0	15.6	1.0	4.4	12.1
	3.0	5.2	12.1	12.3	7.9	0.8	14.9	15.8	3.0	5.2	12.1	16.1	1.0	4.5	12.5
80	1.5	1.6	3.6	10.9	7.3	0.9	14.1	11.7	1.5	1.6	3.6	16.3	1.0	4.5	12.7
	2.3	3.2	7.5	11.4	7.5	0.9	14.4	12.9	2.3	3.2	7.5	17.1	1.1	4.7	13.5
	3.0	4.9	11.3	11.6	7.6	0.9	14.5	13.6	3.0	4.9	11.3	17.5	1.1	4.8	13.9
90	1.5	1.5	3.4	10.2	7.0	1.0	13.7	10.0	1.5	1.5	3.4	17.6	1.1	4.8	14.0
	2.3	3.1	7.1	10.7	7.2	1.0	14.0	11.1	2.3	3.1	7.1	18.4	1.1	4.9	14.7
	3.0	4.7	10.8	10.9	7.3	0.9	14.1	11.6	3.0	4.7	10.8	18.9	1.1	5.0	15.1
100	1.5	1.4	3.2	9.4	6.6	1.1	13.2	8.5	Operation Not Recommended						
	2.3	2.9	6.8	9.9	6.8	1.1	13.5	9.4							
	3.0	4.5	10.4	10.1	6.9	1.0	13.6	9.9							
110	1.5	1.3	3.1	8.6	6.3	1.2	12.7	7.2							
	2.3	2.8	6.5	9.1	6.5	1.1	13.0	7.9							
	3.0	4.3	10.0	9.3	6.6	1.1	13.1	8.4							
120	1.5	1.2	2.8	7.8	5.9	1.3	12.2	6.0							
	2.3	2.7	6.1	8.3	6.1	1.2	12.5	6.7							
	3.0	4.1	9.5	8.5	6.2	1.2	12.6	7.0							

Notes:

- Interpolation is permissible; extrapolation is not.
- All entering air conditions are 80°F (26.6°C) DB and 67°F (19.4°C) WB in cooling, and 70°F (21°C) DB in heating.
- Table does not reflect fan or pump power corrections for AHRI/ISO conditions.
- All performance is based upon the lower voltage of dual voltage rated units.
- Performance stated is at the rated power supply; performance may vary as the power supply varies from the rated.
- Operation below 40°F (4.4°C) is based upon 20% methanol antifreeze solution.
- Operation below 60°F (15.5°C) EWT requires optional insulated water/refrigerant circuit.
- See performance correction tables for operating conditions other than those listed above.
- See Performance Data Selection Notes for operation in the shaded areas.
- Performance capacities shown in thousands of Btu/h.
- For unit operation in the shaded area when LWT is below 40°F (4.4°C), antifreeze must be used and the JW3 jumper on the DXM2.5/CXM2 should be clipped. This is due to the potential of the refrigerant temperature being as low as 32°F (0°C) with 40°F (4.4°C) LWT, which may lead to a nuisance cutout due to the activation of the Low Temperature Protection. JW3 should never be clipped for standard range equipment or systems without antifreeze.

Performance Data SC*012 (EC Blower Motor)

Models:
SC
006-060

400 CFM Rated Airflow

EWT °F	WPD			COOLING - EAT 80/67°F					WPD			Heating - EAT 70°F			
	FLOW GPM	PSI	FT	TC	SC	kW	HR	EER	FLOW GPM	PSI	FT	HC	kW	COP	HE
20	Operation Not Recommended								3.0	10.0	23.1	8.1	0.8	2.8	5.2
30	1.5	2.7	6.3	13.7	8.6	0.5	15.5	25.6	1.5	2.7	6.3	9.0	0.9	3.0	6.0
	2.3	5.6	13.0	13.8	8.8	0.5	15.5	28.5	2.3	5.6	13.0	9.3	0.9	3.1	6.4
	3.0	8.5	19.6	13.9	8.8	0.5	15.5	30.1	3.0	8.5	19.6	9.6	0.9	3.2	6.6
40	1.5	2.3	5.4	13.4	8.4	0.6	15.4	22.1	1.5	2.3	5.4	10.4	0.9	3.4	7.3
	2.3	4.8	11.1	13.6	8.6	0.6	15.5	24.5	2.3	4.8	11.1	10.9	0.9	3.5	7.8
	3.0	7.3	16.8	13.7	8.7	0.5	15.5	25.8	3.0	7.3	16.8	11.1	0.9	3.6	8.0
50	1.5	2.0	4.7	12.9	8.2	0.7	15.2	19.1	1.5	2.0	4.7	11.8	0.9	3.7	8.6
	2.3	4.2	9.7	13.2	8.4	0.6	15.4	21.1	2.3	4.2	9.7	12.4	0.9	3.9	9.2
	3.0	6.4	14.7	13.4	8.4	0.6	15.4	22.2	3.0	6.4	14.7	12.8	1.0	3.9	9.5
60	1.5	1.8	4.2	12.4	7.9	0.8	14.9	16.4	1.5	1.8	4.2	13.3	1.0	4.0	10.0
	2.3	3.8	8.7	12.8	8.1	0.7	15.1	18.2	2.3	3.8	8.7	14.0	1.0	4.2	10.7
	3.0	5.7	13.2	12.9	8.2	0.7	15.2	19.1	3.0	5.7	13.2	14.4	1.0	4.3	11.0
70	1.5	1.7	3.8	11.7	7.7	0.8	14.6	14.2	1.5	1.7	3.8	14.8	1.0	4.4	11.4
	2.3	3.4	8.0	12.2	7.8	0.8	14.8	15.6	2.3	3.4	8.0	15.6	1.0	4.5	12.1
	3.0	5.2	12.1	12.4	7.9	0.8	14.9	16.4	3.0	5.2	12.1	16.0	1.0	4.6	12.5
80	1.5	1.6	3.6	11.0	7.4	0.9	14.1	12.1	1.5	1.6	3.6	16.2	1.0	4.6	12.7
	2.3	3.2	7.5	11.5	7.5	0.9	14.4	13.4	2.3	3.2	7.5	17.0	1.0	4.8	13.5
	3.0	4.9	11.3	11.7	7.6	0.8	14.5	14.1	3.0	4.9	11.3	17.5	1.1	4.9	13.9
90	1.5	1.5	3.4	10.3	7.0	1.0	13.7	10.4	1.5	1.5	3.4	17.6	1.1	4.9	14.0
	2.3	3.1	7.1	10.7	7.2	0.9	14.0	11.4	2.3	3.1	7.1	18.4	1.1	5.0	14.7
	3.0	4.7	10.8	11.0	7.3	0.9	14.1	12.0	3.0	4.7	10.8	18.8	1.1	5.1	15.1
100	1.5	1.4	3.2	9.5	6.7	1.1	13.2	8.8	Operation Not Recommended						
	2.3	2.9	6.8	10.0	6.9	1.0	13.5	9.7							
	3.0	4.5	10.4	10.2	7.0	1.0	13.6	10.2							
110	1.5	1.3	3.1	8.7	6.3	1.2	12.7	7.4							
	2.3	2.8	6.5	9.2	6.5	1.1	13.0	8.2							
	3.0	4.3	10.0	9.4	6.6	1.1	13.1	8.6							
120	1.5	1.2	2.8	7.9	6.0	1.3	12.2	6.2							
	2.3	2.7	6.1	8.3	6.2	1.2	12.5	6.9							
	3.0	4.1	9.5	8.6	6.3	1.2	12.6	7.2							

Notes:

- Interpolation is permissible; extrapolation is not.
- All entering air conditions are 80°F (26.6°C) DB and 67°F (19.4°C) WB in cooling, and 70°F (21°C) DB in heating.
- Table does not reflect fan or pump power corrections for AHRI/ISO conditions.
- All performance is based upon the lower voltage of dual voltage rated units.
- Performance stated is at the rated power supply; performance may vary as the power supply varies from the rated.
- Operation below 40°F (4.4°C) is based upon 20% methanol antifreeze solution.
- Operation below 60°F (15.5°C) EWT requires optional insulated water/refrigerant circuit.
- See performance correction tables for operating conditions other than those listed above.
- See Performance Data Selection Notes for operation in the shaded areas.
- Performance capacities shown in thousands of Btu/h.
- For unit operation in the shaded area when LWT is below 40°F (4.4°C), antifreeze must be used and the JW3 jumper on the DXM2.5/CXM2 should be clipped. This is due to the potential of the refrigerant temperature being as low as 32°F (0°C) with 40°F (4.4°C) LWT, which may lead to a nuisance cutout due to the activation of the Low Temperature Protection. JW3 should never be clipped for standard range equipment or systems without antifreeze.

Performance Data SC*015 (PSC Blower Motor)

Models:
SC
006-060

525 CFM Rated Airflow

EWT °F	WPD			COOLING - EAT 80/67°F					WPD			Heating - EAT 70°F			
	FLOW GPM	PSI	FT	TC	SC	kW	HR	EER	FLOW GPM	PSI	FT	HC	kW	COP	HE
20	Operation Not Recommended								3.8	5.3	12.3	9.5	0.9	2.9	6.2
30	1.9	1.8	4.1	17.5	12.3	0.6	19.6	28.4	1.9	1.8	4.1	10.6	1.0	3.2	7.3
	2.8	3.1	7.1	17.6	12.2	0.6	19.5	31.1	2.8	3.1	7.1	11.0	1.0	3.3	7.7
	3.8	4.4	10.2	17.6	12.0	0.5	19.4	32.6	3.8	4.4	10.2	11.3	1.0	3.3	7.9
40	1.9	1.5	3.4	17.2	12.2	0.7	19.6	24.7	1.9	1.5	3.4	12.2	1.0	3.5	8.8
	2.8	2.6	6.0	17.4	12.3	0.6	19.6	27.2	2.8	2.6	6.0	12.7	1.0	3.7	9.3
	3.8	3.7	8.6	17.5	12.3	0.6	19.6	28.6	3.8	3.7	8.6	13.0	1.0	3.7	9.5
50	1.9	1.3	2.9	16.8	11.9	0.8	19.5	21.5	1.9	1.3	2.9	13.8	1.0	3.9	10.3
	2.8	2.3	5.3	17.1	12.2	0.7	19.6	23.7	2.8	2.3	5.3	14.4	1.1	4.0	10.9
	3.8	3.3	7.6	17.2	12.3	0.7	19.6	24.9	3.8	3.3	7.6	14.8	1.1	4.1	11.2
60	1.9	1.2	2.7	16.2	11.5	0.9	19.2	18.5	1.9	1.2	2.7	15.4	1.1	4.2	11.8
	2.8	2.1	4.8	16.6	11.8	0.8	19.4	20.5	2.8	2.1	4.8	16.1	1.1	4.4	12.4
	3.8	3.0	7.0	16.8	12.0	0.8	19.5	21.6	3.8	3.0	7.0	16.5	1.1	4.4	12.8
70	1.9	1.1	2.5	15.5	11.1	1.0	18.8	15.9	1.9	1.1	2.5	17.0	1.1	4.5	13.3
	2.8	2.0	4.6	16.0	11.4	0.9	19.1	17.7	2.8	2.0	4.6	17.8	1.1	4.7	14.0
	3.8	2.9	6.6	16.2	11.5	0.9	19.2	18.6	3.8	2.9	6.6	18.2	1.1	4.8	14.4
80	1.9	1.1	2.5	14.7	10.6	1.1	18.3	13.6	1.9	1.1	2.5	18.6	1.1	4.8	14.8
	2.8	1.9	4.5	15.2	10.9	1.0	18.7	15.1	2.8	1.9	4.5	19.5	1.1	5.0	15.6
	3.8	2.8	6.5	15.5	11.1	1.0	18.8	15.9	3.8	2.8	6.5	19.9	1.1	5.1	16.0
90	1.9	1.1	2.5	13.7	10.2	1.2	17.7	11.6	1.9	1.1	2.5	20.2	1.2	5.1	16.3
	2.8	1.9	4.5	14.3	10.5	1.1	18.1	12.9	2.8	1.9	4.5	21.1	1.2	5.3	17.2
	3.8	2.8	6.4	14.6	10.6	1.1	18.3	13.6	3.8	2.8	6.4	21.7	1.2	5.4	17.7
100	1.9	1.1	2.5	12.6	9.9	1.3	17.0	9.7	Operation Not Recommended						
	2.8	1.9	4.4	13.3	10.1	1.2	17.4	10.8							
	3.8	2.7	6.3	13.6	10.2	1.2	17.7	11.5							
110	1.9	1.0	2.4	11.4	9.7	1.4	16.2	8.1							
	2.8	1.8	4.3	12.1	9.8	1.3	16.7	9.0							
	3.8	2.6	6.1	12.5	9.9	1.3	16.9	9.6							
120	1.9	0.9	2.2	10.1	9.4	1.5	15.3	6.6							
	2.8	1.7	3.9	10.8	9.6	1.5	15.8	7.4							
	3.8	2.4	5.6	11.2	9.6	1.4	16.0	7.9							

Notes:

- Interpolation is permissible; extrapolation is not.
- All entering air conditions are 80°F (26.6°C) DB and 67°F (19.4°C) WB in cooling, and 70°F (21°C) DB in heating.
- Table does not reflect fan or pump power corrections for AHRI/ISO conditions.
- All performance is based upon the lower voltage of dual voltage rated units.
- Performance stated is at the rated power supply; performance may vary as the power supply varies from the rated.
- Operation below 40°F (4.4°C) is based upon 20% methanol antifreeze solution.
- Operation below 60°F (15.5°C) EWT requires optional insulated water/refrigerant circuit.
- See performance correction tables for operating conditions other than those listed above.
- See Performance Data Selection Notes for operation in the shaded areas.
- Performance capacities shown in thousands of Btu/h.
- For unit operation in the shaded area when LWT is below 40°F (4.4°C), antifreeze must be used and the JW3 jumper on the DXM2.5/CXM2 should be clipped. This is due to the potential of the refrigerant temperature being as low as 32°F (0°C) with 40°F (4.4°C) LWT, which may lead to a nuisance cutout due to the activation of the Low Temperature Protection. JW3 should never be clipped for standard range equipment or systems without antifreeze.

Performance Data SC*015 (EC Blower Motor)

Models:
SC
006-060

525 CFM Rated Airflow

EWT °F	WPD			COOLING - EAT 80/67°F					WPD			Heating - EAT 70°F			
	FLOW GPM	PSI	FT	TC	SC	kW	HR	EER	FLOW GPM	PSI	FT	HC	kW	COP	HE
20	Operation Not Recommended								3.8	5.3	12.3	9.4	0.9	3.0	6.2
30	1.9	1.8	4.1	17.6	12.4	0.6	19.6	30.0	1.9	1.8	4.1	10.5	0.9	3.3	7.3
	2.8	3.1	7.1	17.7	12.2	0.5	19.5	33.1	2.8	3.1	7.1	10.9	1.0	3.4	7.7
	3.8	4.4	10.2	17.7	12.1	0.5	19.4	34.7	3.8	4.4	10.2	11.2	1.0	3.4	7.9
40	1.9	1.5	3.4	17.3	12.3	0.7	19.6	26.0	1.9	1.5	3.4	12.1	1.0	3.6	8.8
	2.8	2.6	6.0	17.5	12.4	0.6	19.6	28.7	2.8	2.6	6.0	12.6	1.0	3.7	9.3
	3.8	3.7	8.6	17.6	12.4	0.6	19.6	30.2	3.8	3.7	8.6	12.9	1.0	3.8	9.5
50	1.9	1.3	2.9	16.9	12.0	0.8	19.5	22.5	1.9	1.3	2.9	13.7	1.0	4.0	10.3
	2.8	2.3	5.3	17.2	12.2	0.7	19.6	24.9	2.8	2.3	5.3	14.3	1.0	4.1	10.9
	3.8	3.3	7.6	17.3	12.3	0.7	19.6	26.2	3.8	3.3	7.6	14.7	1.0	4.2	11.2
60	1.9	1.2	2.7	16.3	11.6	0.8	19.2	19.3	1.9	1.2	2.7	15.3	1.0	4.3	11.8
	2.8	2.1	4.8	16.7	11.9	0.8	19.4	21.4	2.8	2.1	4.8	16.0	1.1	4.5	12.4
	3.8	3.0	7.0	16.9	12.0	0.7	19.5	22.6	3.8	3.0	7.0	16.4	1.1	4.5	12.8
70	1.9	1.1	2.5	15.6	11.1	0.9	18.8	16.6	1.9	1.1	2.5	16.9	1.1	4.6	13.3
	2.8	2.0	4.6	16.1	11.4	0.9	19.1	18.4	2.8	2.0	4.6	17.7	1.1	4.8	14.0
	3.8	2.9	6.6	16.3	11.6	0.8	19.2	19.4	3.8	2.9	6.6	18.1	1.1	4.9	14.4
80	1.9	1.1	2.5	14.8	10.7	1.0	18.3	14.1	1.9	1.1	2.5	18.5	1.1	4.9	14.8
	2.8	1.9	4.5	15.3	11.0	1.0	18.7	15.7	2.8	1.9	4.5	19.4	1.1	5.1	15.6
	3.8	2.8	6.5	15.6	11.1	0.9	18.8	16.6	3.8	2.8	6.5	19.8	1.1	5.2	16.0
90	1.9	1.1	2.5	13.8	10.3	1.2	17.7	12.0	1.9	1.1	2.5	20.1	1.1	5.2	16.3
	2.8	1.9	4.5	14.4	10.5	1.1	18.1	13.3	2.8	1.9	4.5	21.0	1.1	5.4	17.2
	3.8	2.8	6.4	14.7	10.7	1.0	18.3	14.1	3.8	2.8	6.4	21.6	1.1	5.5	17.7
100	1.9	1.1	2.5	12.7	10.0	1.3	17.0	10.1	Operation Not Recommended						
	2.8	1.9	4.4	13.4	10.2	1.2	17.4	11.2							
	3.8	2.7	6.3	13.7	10.3	1.2	17.7	11.8							
110	1.9	1.0	2.4	11.5	9.8	1.4	16.2	8.4							
	2.8	1.8	4.3	12.2	9.9	1.3	16.7	9.3							
	3.8	2.6	6.1	12.6	10.0	1.3	16.9	9.9							
120	1.9	0.9	2.2	10.2	9.5	1.5	15.3	6.8							
	2.8	1.7	3.9	10.9	9.7	1.4	15.8	7.7							
	3.8	2.4	5.6	11.3	9.7	1.4	16.0	8.1							

Notes:

- Interpolation is permissible; extrapolation is not.
- All entering air conditions are 80°F (26.6°C) DB and 67°F (19.4°C) WB in cooling, and 70°F (21°C) DB in heating.
- Table does not reflect fan or pump power corrections for AHRI/ISO conditions.
- All performance is based upon the lower voltage of dual voltage rated units.
- Performance stated is at the rated power supply; performance may vary as the power supply varies from the rated.
- Operation below 40°F (4.4°C) is based upon 20% methanol antifreeze solution.
- Operation below 60°F (15.5°C) EWT requires optional insulated water/refrigerant circuit.
- See performance correction tables for operating conditions other than those listed above.
- See Performance Data Selection Notes for operation in the shaded areas.
- Performance capacities shown in thousands of Btu/h.
- For unit operation in the shaded area when LWT is below 40°F (4.4°C), antifreeze must be used and the JW3 jumper on the DXM2.5/CXM2 should be clipped. This is due to the potential of the refrigerant temperature being as low as 32°F (0°C) with 40°F (4.4°C) LWT, which may lead to a nuisance cutout due to the activation of the Low Temperature Protection. JW3 should never be clipped for standard range equipment or systems without antifreeze.

Performance Data SC*018 (PSC Blower Motor)

Models:
SC
006-060

630 CFM Rated Airflow

EWT °F	WPD			COOLING - EAT 80/67°F					WPD			Heating - EAT 70°F			
	FLOW GPM	PSI	FT	TC	SC	kW	HR	EER	FLOW GPM	PSI	FT	HC	kW	COP	HE
20	Operation Not Recommended								4.5	9.2	21.1	11.9	1.2	3.0	7.9
30	2.3	2.7	6.3	23.0	15.7	0.8	25.6	29.8	2.3	2.7	6.3	13.2	1.2	3.2	9.1
	3.4	5.2	12.1	23.5	16.0	0.7	25.9	33.8	3.4	5.2	12.1	13.8	1.2	3.3	9.7
	4.5	7.7	17.9	23.8	16.2	0.7	26.1	36.0	4.5	7.7	17.9	14.1	1.2	3.4	10.0
40	2.3	2.4	5.6	22.2	15.3	0.9	25.2	25.3	2.3	2.4	5.6	15.3	1.2	3.6	11.0
	3.4	4.6	10.5	22.8	15.6	0.8	25.5	28.7	3.4	4.6	10.5	16.0	1.3	3.7	11.7
	4.5	6.7	15.4	23.1	15.8	0.8	25.7	30.5	4.5	6.7	15.4	16.4	1.3	3.8	12.0
50	2.3	2.2	5.1	21.4	15.0	1.0	24.8	21.5	2.3	2.2	5.1	17.3	1.3	3.9	12.9
	3.4	4.1	9.4	22.0	15.2	0.9	25.1	24.3	3.4	4.1	9.4	18.1	1.3	4.0	13.6
	4.5	5.9	13.7	22.3	15.4	0.9	25.3	25.8	4.5	5.9	13.7	18.5	1.3	4.1	14.0
60	2.3	2.1	4.8	20.6	14.6	1.1	24.4	18.2	2.3	2.1	4.8	19.3	1.3	4.2	14.7
	3.4	3.8	8.7	21.2	14.9	1.0	24.7	20.5	3.4	3.8	8.7	20.2	1.4	4.4	15.6
	4.5	5.4	12.6	21.5	15.0	1.0	24.9	21.8	4.5	5.4	12.6	20.7	1.4	4.4	16.0
70	2.3	2.0	4.5	19.7	14.2	1.3	24.0	15.5	2.3	2.0	4.5	21.2	1.4	4.5	16.5
	3.4	3.5	8.2	20.3	14.5	1.2	24.3	17.4	3.4	3.5	8.2	22.2	1.4	4.7	17.4
	4.5	5.1	11.9	20.7	14.6	1.1	24.5	18.5	4.5	5.1	11.9	22.8	1.4	4.7	17.9
80	2.3	1.9	4.4	18.7	13.8	1.4	23.5	13.1	2.3	1.9	4.4	23.1	1.4	4.8	18.3
	3.4	3.4	7.9	19.4	14.1	1.3	23.9	14.7	3.4	3.4	7.9	24.2	1.4	4.9	19.3
	4.5	5.0	11.5	19.7	14.3	1.3	24.0	15.6	4.5	5.0	11.5	24.8	1.4	5.0	19.8
90	2.3	1.8	4.2	17.6	13.3	1.6	23.0	11.1	2.3	1.8	4.2	25.0	1.4	5.1	20.0
	3.4	3.3	7.7	18.3	13.7	1.5	23.3	12.5	3.4	3.3	7.7	26.1	1.5	5.2	21.1
	4.5	4.9	11.2	18.7	13.8	1.4	23.5	13.2	4.5	4.9	11.2	26.7	1.5	5.3	21.7
100	2.3	1.8	4.1	16.3	12.8	1.7	22.3	9.4	Operation Not Recommended						
	3.4	3.3	7.5	17.2	13.1	1.6	22.8	10.5							
	4.5	4.8	11.0	17.6	13.3	1.6	23.0	11.1							
110	2.3	1.7	3.9	15.0	12.1	1.9	21.6	7.8							
	3.4	3.2	7.3	15.9	12.5	1.8	22.1	8.8							
	4.5	4.6	10.6	16.3	12.8	1.7	22.3	9.3							
120	2.3	1.6	3.7	13.6	11.3	2.1	20.7	6.5							
	3.4	3.0	6.9	14.5	11.8	2.0	21.3	7.3							
	4.5	4.3	10.0	15.0	12.1	1.9	21.5	7.8							

Notes:

- Interpolation is permissible; extrapolation is not.
- All entering air conditions are 80°F (26.6°C) DB and 67°F (19.4°C) WB in cooling, and 70°F (21°C) DB in heating.
- Table does not reflect fan or pump power corrections for AHRI/ISO conditions.
- All performance is based upon the lower voltage of dual voltage rated units.
- Performance stated is at the rated power supply; performance may vary as the power supply varies from the rated.
- Operation below 40°F (4.4°C) is based upon 20% methanol antifreeze solution.
- Operation below 60°F (15.5°C) EWT requires optional insulated water/refrigerant circuit.
- See performance correction tables for operating conditions other than those listed above.
- See Performance Data Selection Notes for operation in the shaded areas.
- Performance capacities shown in thousands of Btu/h.
- For unit operation in the shaded area when LWT is below 40°F (4.4°C), antifreeze must be used and the JW3 jumper on the DXM2.5/CXM2 should be clipped. This is due to the potential of the refrigerant temperature being as low as 32°F (0°C) with 40°F (4.4°C) LWT, which may lead to a nuisance cutout due to the activation of the Low Temperature Protection. JW3 should never be clipped for standard range equipment or systems without antifreeze.

Performance Data SC*018 (EC Blower Motor)

Models:
SC
006-060

630 CFM Rated Airflow

EWT °F	WPD			COOLING - EAT 80/67°F					WPD			Heating - EAT 70°F			
	FLOW GPM	PSI	FT	TC	SC	kW	HR	EER	FLOW GPM	PSI	FT	HC	kW	COP	HE
20	Operation Not Recommended								4.5	9.2	21.1	11.8	1.1	3.0	7.9
30	2.3	2.7	6.3	23.1	15.8	0.8	25.6	30.7	2.3	2.7	6.3	13.1	1.2	3.3	9.1
	3.4	5.2	12.1	23.6	16.1	0.7	25.9	34.9	3.4	5.2	12.1	13.7	1.2	3.4	9.7
	4.5	7.7	17.9	23.9	16.2	0.6	26.1	37.2	4.5	7.7	17.9	14.1	1.2	3.4	10.0
40	2.3	2.4	5.6	22.3	15.4	0.9	25.2	26.0	2.3	2.4	5.6	15.2	1.2	3.6	11.0
	3.4	4.6	10.5	22.9	15.7	0.8	25.5	29.5	3.4	4.6	10.5	15.9	1.2	3.7	11.7
	4.5	6.7	15.4	23.2	15.8	0.7	25.7	31.4	4.5	6.7	15.4	16.3	1.3	3.8	12.0
50	2.3	2.2	5.1	21.5	15.0	1.0	24.8	22.0	2.3	2.2	5.1	17.2	1.3	4.0	12.9
	3.4	4.1	9.4	22.1	15.3	0.9	25.1	24.9	3.4	4.1	9.4	18.0	1.3	4.1	13.6
	4.5	5.9	13.7	22.4	15.4	0.8	25.3	26.5	4.5	5.9	13.7	18.5	1.3	4.2	14.0
60	2.3	2.1	4.8	20.7	14.7	1.1	24.4	18.6	2.3	2.1	4.8	19.2	1.3	4.3	14.7
	3.4	3.8	8.7	21.3	14.9	1.0	24.7	21.0	3.4	3.8	8.7	20.1	1.3	4.4	15.6
	4.5	5.4	12.6	21.6	15.1	1.0	24.9	22.4	4.5	5.4	12.6	20.6	1.3	4.5	16.0
70	2.3	2.0	4.5	19.7	14.3	1.3	24.0	15.8	2.3	2.0	4.5	21.2	1.4	4.6	16.5
	3.4	3.5	8.2	20.4	14.6	1.1	24.3	17.8	3.4	3.5	8.2	22.2	1.4	4.7	17.4
	4.5	5.1	11.9	20.7	14.7	1.1	24.5	18.9	4.5	5.1	11.9	22.7	1.4	4.8	17.9
80	2.3	1.9	4.4	18.7	13.8	1.4	23.5	13.3	2.3	1.9	4.4	23.1	1.4	4.8	18.3
	3.4	3.4	7.9	19.4	14.2	1.3	23.9	15.0	3.4	3.4	7.9	24.1	1.4	5.0	19.3
	4.5	5.0	11.5	19.8	14.3	1.2	24.0	15.9	4.5	5.0	11.5	24.7	1.4	5.1	19.8
90	2.3	1.8	4.2	17.6	13.4	1.6	23.0	11.3	2.3	1.8	4.2	24.9	1.4	5.1	20.0
	3.4	3.3	7.7	18.4	13.7	1.5	23.3	12.7	3.4	3.3	7.7	26.0	1.4	5.3	21.1
	4.5	4.9	11.2	18.8	13.9	1.4	23.5	13.4	4.5	4.9	11.2	26.6	1.5	5.4	21.7
100	2.3	1.8	4.1	16.4	12.8	1.7	22.3	9.5	Operation Not Recommended						
	3.4	3.3	7.5	17.2	13.2	1.6	22.8	10.7							
	4.5	4.8	11.0	17.6	13.4	1.6	23.0	11.3							
110	2.3	1.7	3.9	15.1	12.1	1.9	21.6	7.9							
	3.4	3.2	7.3	16.0	12.6	1.8	22.1	8.9							
	4.5	4.6	10.6	16.4	12.8	1.7	22.3	9.5							
120	2.3	1.6	3.7	13.7	11.4	2.1	20.7	6.6							
	3.4	3.0	6.9	14.6	11.9	2.0	21.3	7.4							
	4.5	4.3	10.0	15.0	12.1	1.9	21.5	7.9							

Notes:

- Interpolation is permissible; extrapolation is not.
- All entering air conditions are 80°F (26.6°C) DB and 67°F (19.4°C) WB in cooling, and 70°F (21°C) DB in heating.
- Table does not reflect fan or pump power corrections for AHRI/ISO conditions.
- All performance is based upon the lower voltage of dual voltage rated units.
- Performance stated is at the rated power supply; performance may vary as the power supply varies from the rated.
- Operation below 40°F (4.4°C) is based upon 20% methanol antifreeze solution.
- Operation below 60°F (15.5°C) EWT requires optional insulated water/refrigerant circuit.
- See performance correction tables for operating conditions other than those listed above.
- See Performance Data Selection Notes for operation in the shaded areas.
- Performance capacities shown in thousands of Btu/h.
- For unit operation in the shaded area when LWT is below 40°F (4.4°C), antifreeze must be used and the JW3 jumper on the DXM2.5/CXM2 should be clipped. This is due to the potential of the refrigerant temperature being as low as 32°F (0°C) with 40°F (4.4°C) LWT, which may lead to a nuisance cutout due to the activation of the Low Temperature Protection. JW3 should never be clipped for standard range equipment or systems without antifreeze.

Performance Data SC*024 (PSC Blower Motor)

Models:
SC
006-060

800 CFM Rated Airflow

EWT °F	WPD			COOLING - EAT 80/67°F					WPD			Heating - EAT 70°F			
	FLOW GPM	PSI	FT	TC	SC	kW	HR	EER	FLOW GPM	PSI	FT	HC	kW	COP	HE
20	Operation Not Recommended								6.0	4.2	9.6	17.1	1.7	3.0	11.4
30	3.0	1.2	2.7	27.7	18.7	1.1	31.3	26.2	3.0	1.2	2.7	18.7	1.7	3.2	13.0
	4.5	2.3	5.3	27.1	18.2	1.0	30.5	27.3	4.5	2.3	5.3	19.6	1.7	3.4	13.7
	6.0	3.3	7.7	26.7	17.9	1.0	30.0	27.6	6.0	3.3	7.7	20.0	1.7	3.4	14.2
40	3.0	0.9	2.1	27.9	19.0	1.2	31.9	23.8	3.0	0.9	2.1	21.5	1.7	3.6	15.5
	4.5	1.8	4.2	27.9	18.9	1.1	31.6	25.6	4.5	1.8	4.2	22.5	1.8	3.7	16.4
	6.0	2.7	6.3	27.7	18.7	1.1	31.3	26.3	6.0	2.7	6.3	23.0	1.8	3.8	17.0
50	3.0	0.7	1.7	27.6	19.0	1.3	32.0	21.0	3.0	0.7	1.7	24.2	1.8	3.9	18.1
	4.5	1.5	3.4	27.9	19.0	1.2	32.0	23.0	4.5	1.5	3.4	25.4	1.8	4.1	19.2
	6.0	2.3	5.4	27.9	19.0	1.2	31.9	24.0	6.0	2.3	5.4	26.0	1.8	4.2	19.8
60	3.0	0.6	1.4	26.8	18.7	1.5	31.8	18.2	3.0	0.6	1.4	27.0	1.9	4.3	20.6
	4.5	1.3	3.0	27.4	18.9	1.4	32.0	20.2	4.5	1.3	3.0	28.3	1.9	4.4	21.9
	6.0	2.1	4.8	27.6	19.0	1.3	32.0	21.2	6.0	2.1	4.8	29.0	1.9	4.5	22.5
70	3.0	0.6	1.3	25.7	18.2	1.7	31.3	15.5	3.0	0.6	1.3	29.7	1.9	4.6	23.2
	4.5	1.2	2.7	26.5	18.6	1.5	31.7	17.4	4.5	1.2	2.7	31.2	1.9	4.7	24.5
	6.0	2.0	4.5	26.8	18.7	1.5	31.8	18.3	6.0	2.0	4.5	32.0	2.0	4.8	25.3
80	3.0	0.5	1.2	24.4	17.7	1.9	30.8	13.1	3.0	0.5	1.2	32.4	2.0	4.8	25.7
	4.5	1.1	2.6	25.3	18.1	1.7	31.2	14.7	4.5	1.1	2.6	33.9	2.0	5.0	27.1
	6.0	1.9	4.3	25.7	18.3	1.6	31.3	15.6	6.0	1.9	4.3	34.8	2.0	5.1	27.9
90	3.0	0.5	1.1	23.1	17.0	2.1	30.2	11.0	3.0	0.5	1.1	35.0	2.0	5.1	28.1
	4.5	1.1	2.5	24.0	17.5	1.9	30.6	12.4	4.5	1.1	2.5	36.6	2.1	5.2	29.6
	6.0	1.8	4.3	24.4	17.7	1.9	30.8	13.1	6.0	1.8	4.3	37.5	2.1	5.3	30.4
100	3.0	0.5	1.1	21.7	16.4	2.4	29.8	9.2	Operation Not Recommended						
	4.5	1.1	2.4	22.6	16.8	2.2	30.1	10.3							
	6.0	1.8	4.1	23.1	17.0	2.1	30.2	11.0							
110	3.0	0.4	0.9	20.6	15.9	2.7	29.7	7.7							
	4.5	1.0	2.2	21.3	16.2	2.5	29.7	8.6							
	6.0	1.7	3.9	21.7	16.4	2.4	29.8	9.2							
120	3.0	0.3	0.7	19.7	15.6	3.0	30.0	6.5							
	4.5	0.8	1.9	20.2	15.8	2.8	29.7	7.3							
	6.0	1.5	3.4	20.6	15.9	2.7	29.7	7.7							

Notes:

- Interpolation is permissible; extrapolation is not.
- All entering air conditions are 80°F (26.6°C) DB and 67°F (19.4°C) WB in cooling, and 70°F (21°C) DB in heating.
- Table does not reflect fan or pump power corrections for AHRI/ISO conditions.
- All performance is based upon the lower voltage of dual voltage rated units.
- Performance stated is at the rated power supply; performance may vary as the power supply varies from the rated.
- Operation below 40°F (4.4°C) is based upon 20% methanol antifreeze solution.
- Operation below 60°F (15.5°C) EWT requires optional insulated water/refrigerant circuit.
- See performance correction tables for operating conditions other than those listed above.
- See Performance Data Selection Notes for operation in the shaded areas.
- Performance capacities shown in thousands of Btu/h.
- For unit operation in the shaded area when LWT is below 40°F (4.4°C), antifreeze must be used and the JW3 jumper on the DXM2.5/CXM2 should be clipped. This is due to the potential of the refrigerant temperature being as low as 32°F (0°C) with 40°F (4.4°C) LWT, which may lead to a nuisance cutout due to the activation of the Low Temperature Protection. JW3 should never be clipped for standard range equipment or systems without antifreeze.

Performance Data SC*024 (EC Blower Motor)

Models:
SC
006-060

800 CFM Rated Airflow

EWT °F	WPD			COOLING - EAT 80/67°F					WPD			Heating - EAT 70°F			
	FLOW GPM	PSI	FT	TC	SC	kW	HR	EER	FLOW GPM	PSI	FT	HC	kW	COP	HE
20	Operation Not Recommended								6.0	4.2	9.6	17.0	1.6	3.1	11.5
30	3.0	1.2	2.7	27.7	18.7	1.0	31.2	27.2	3.0	1.2	2.7	18.6	1.7	3.3	13.0
	4.5	2.3	5.3	27.1	18.2	1.0	30.3	28.4	4.5	2.3	5.3	19.5	1.7	3.4	13.8
	6.0	3.3	7.7	26.6	17.9	0.9	29.8	28.8	6.0	3.3	7.7	19.9	1.7	3.5	14.2
40	3.0	0.9	2.1	27.9	19.0	1.1	31.8	24.7	3.0	0.9	2.1	21.4	1.7	3.7	15.5
	4.5	1.8	4.2	27.8	18.8	1.0	31.4	26.5	4.5	1.8	4.2	22.4	1.7	3.8	16.5
	6.0	2.7	6.3	27.7	18.7	1.0	31.1	27.3	6.0	2.7	6.3	22.9	1.7	3.9	17.0
50	3.0	0.7	1.7	27.5	19.0	1.3	31.9	21.7	3.0	0.7	1.7	24.1	1.8	4.0	18.1
	4.5	1.5	3.4	27.9	19.0	1.2	31.9	23.8	4.5	1.5	3.4	25.3	1.8	4.1	19.2
	6.0	2.3	5.4	27.9	19.0	1.1	31.8	24.8	6.0	2.3	5.4	25.9	1.8	4.2	19.8
60	3.0	0.6	1.4	26.7	18.7	1.4	31.6	18.7	3.0	0.6	1.4	26.8	1.8	4.3	20.6
	4.5	1.3	3.0	27.3	18.9	1.3	31.8	20.8	4.5	1.3	3.0	28.2	1.8	4.5	21.9
	6.0	2.1	4.8	27.6	19.0	1.3	31.9	21.9	6.0	2.1	4.8	28.9	1.9	4.6	22.5
70	3.0	0.6	1.3	25.7	18.2	1.6	31.2	15.9	3.0	0.6	1.3	29.5	1.9	4.6	23.2
	4.5	1.2	2.7	26.4	18.6	1.5	31.5	17.8	4.5	1.2	2.7	31.0	1.9	4.8	24.5
	6.0	2.0	4.5	26.8	18.7	1.4	31.7	18.8	6.0	2.0	4.5	31.8	1.9	4.9	25.2
80	3.0	0.5	1.2	24.4	17.6	1.8	30.6	13.4	3.0	0.5	1.2	32.2	1.9	4.9	25.6
	4.5	1.1	2.6	25.3	18.1	1.7	31.0	15.1	4.5	1.1	2.6	33.8	2.0	5.1	27.1
	6.0	1.9	4.3	25.7	18.2	1.6	31.2	16.0	6.0	1.9	4.3	34.6	2.0	5.1	27.9
90	3.0	0.5	1.1	23.0	17.0	2.1	30.1	11.2	3.0	0.5	1.1	34.8	2.0	5.1	28.0
	4.5	1.1	2.5	23.9	17.4	1.9	30.4	12.6	4.5	1.1	2.5	36.4	2.0	5.3	29.6
	6.0	1.8	4.3	24.4	17.7	1.8	30.6	13.4	6.0	1.8	4.3	37.3	2.0	5.4	30.4
100	3.0	0.5	1.1	21.7	16.4	2.3	29.7	9.3	Operation Not Recommended						
	4.5	1.1	2.4	22.6	16.8	2.1	29.9	10.5							
	6.0	1.8	4.1	23.0	17.0	2.1	30.1	11.2							
110	3.0	0.4	0.9	20.6	15.9	2.6	29.5	7.8							
	4.5	1.0	2.2	21.3	16.2	2.4	29.6	8.8							
	6.0	1.7	3.9	21.7	16.4	2.3	29.7	9.3							
120	3.0	0.3	0.7	19.7	15.6	3.0	29.8	6.6							
	4.5	0.8	1.9	20.2	15.8	2.7	29.6	7.4							
	6.0	1.5	3.4	20.5	15.9	2.6	29.5	7.8							

Notes:

- Interpolation is permissible; extrapolation is not.
- All entering air conditions are 80°F (26.6°C) DB and 67°F (19.4°C) WB in cooling, and 70°F (21°C) DB in heating.
- Table does not reflect fan or pump power corrections for AHRI/ISO conditions.
- All performance is based upon the lower voltage of dual voltage rated units.
- Performance stated is at the rated power supply; performance may vary as the power supply varies from the rated.
- Operation below 40°F (4.4°C) is based upon 20% methanol antifreeze solution.
- Operation below 60°F (15.5°C) EWT requires optional insulated water/refrigerant circuit.
- See performance correction tables for operating conditions other than those listed above.
- See Performance Data Selection Notes for operation in the shaded areas.
- Performance capacities shown in thousands of Btu/h.
- For unit operation in the shaded area when LWT is below 40°F (4.4°C), antifreeze must be used and the JW3 jumper on the DXM2.5/CXM2 should be clipped. This is due to the potential of the refrigerant temperature being as low as 32°F (0°C) with 40°F (4.4°C) LWT, which may lead to a nuisance cutout due to the activation of the Low Temperature Protection. JW3 should never be clipped for standard range equipment or systems without antifreeze.

Performance Data SC*030 (PSC Blower Motor)

Models:
SC
006-060

1,000 CFM Rated Airflow

EWT °F	WPD			COOLING - EAT 80/67°F					WPD			Heating - EAT 70°F			
	FLOW GPM	PSI	FT	TC	SC	kW	HR	EER	FLOW GPM	PSI	FT	HC	kW	COP	HE
20	Operation Not Recommended								7.5	6.6	15.3	20.0	2.0	3.0	13.2
30	3.8	2.0	4.6	33.5	23.1	1.3	37.9	26.1	3.8	2.0	4.6	22.0	2.0	3.2	15.1
	5.6	3.7	8.5	33.4	23.0	1.2	37.5	27.6	5.6	3.7	8.5	22.8	2.0	3.3	15.8
	7.5	5.3	12.3	33.2	22.9	1.2	37.3	28.3	7.5	5.3	12.3	23.2	2.1	3.3	16.2
40	3.8	1.6	3.6	33.2	23.0	1.4	38.1	23.4	3.8	1.6	3.6	25.0	2.1	3.5	17.8
	5.6	2.9	6.7	33.5	23.1	1.3	38.0	25.2	5.6	2.9	6.7	25.9	2.1	3.6	18.7
	7.5	4.4	10.1	33.5	23.1	1.3	37.9	26.0	7.5	4.4	10.1	26.4	2.1	3.7	19.2
50	3.8	1.3	3.0	32.5	22.8	1.6	37.8	20.7	3.8	1.3	3.0	27.9	2.1	3.8	20.6
	5.6	2.4	5.5	33.0	23.0	1.5	38.0	22.4	5.6	2.4	5.5	29.0	2.2	3.9	21.6
	7.5	3.8	8.7	33.2	23.0	1.4	38.1	23.4	7.5	3.8	8.7	29.6	2.2	4.0	22.1
60	3.8	1.1	2.5	31.3	22.5	1.7	37.3	17.9	3.8	1.1	2.5	30.8	2.2	4.1	23.3
	5.6	2.1	4.8	32.1	22.7	1.6	37.7	19.7	5.6	2.1	4.8	32.0	2.2	4.2	24.4
	7.5	3.4	7.8	32.4	22.8	1.6	37.8	20.6	7.5	3.4	7.8	32.7	2.2	4.3	25.1
70	3.8	1.0	2.3	29.9	22.0	2.0	36.6	15.3	3.8	1.0	2.3	33.7	2.3	4.4	26.0
	5.6	1.9	4.4	30.8	22.3	1.8	37.1	16.9	5.6	1.9	4.4	35.1	2.3	4.5	27.3
	7.5	3.2	7.3	31.3	22.5	1.8	37.3	17.8	7.5	3.2	7.3	35.9	2.3	4.5	28.0
80	3.8	1.0	2.2	28.3	21.4	2.2	35.8	13.0	3.8	1.0	2.2	36.7	2.3	4.6	28.7
	5.6	1.9	4.3	29.3	21.8	2.0	36.3	14.4	5.6	1.9	4.3	38.2	2.4	4.7	30.1
	7.5	3.1	7.1	29.9	22.0	2.0	36.6	15.2	7.5	3.1	7.1	39.1	2.4	4.8	30.9
90	3.8	0.9	2.1	26.6	20.7	2.5	35.0	10.9	3.8	0.9	2.1	39.6	2.4	4.9	31.5
	5.6	1.8	4.2	27.7	21.1	2.3	35.5	12.1	5.6	1.8	4.2	41.3	2.4	5.0	33.0
	7.5	3.0	7.0	28.2	21.4	2.2	35.7	12.8	7.5	3.0	7.0	42.3	2.4	5.1	33.9
100	3.8	0.9	2.0	24.8	19.9	2.8	34.3	9.0	Operation Not Recommended						
	5.6	1.8	4.1	25.9	20.4	2.6	34.7	10.1							
	7.5	3.0	6.9	26.4	20.6	2.5	34.9	10.7							
110	3.8	0.8	1.9	23.1	19.1	3.1	33.7	7.4							
	5.6	1.7	3.8	24.1	19.6	2.9	34.0	8.3							
	7.5	2.8	6.5	24.6	19.9	2.8	34.2	8.8							
120	3.8	0.7	1.5	21.5	18.3	3.5	33.4	6.1							
	5.6	1.4	3.3	22.4	18.8	3.3	33.5	6.9							
	7.5	2.5	5.8	22.9	19.0	3.1	33.6	7.3							

Notes:

- Interpolation is permissible; extrapolation is not.
- All entering air conditions are 80°F (26.6°C) DB and 67°F (19.4°C) WB in cooling, and 70°F (21°C) DB in heating.
- Table does not reflect fan or pump power corrections for AHRI/ISO conditions.
- All performance is based upon the lower voltage of dual voltage rated units.
- Performance stated is at the rated power supply; performance may vary as the power supply varies from the rated.
- Operation below 40°F (4.4°C) is based upon 20% methanol antifreeze solution.
- Operation below 60°F (15.5°C) EWT requires optional insulated water/refrigerant circuit.
- See performance correction tables for operating conditions other than those listed above.
- See Performance Data Selection Notes for operation in the shaded areas.
- Performance capacities shown in thousands of Btu/h.
- For unit operation in the shaded area when LWT is below 40°F (4.4°C), antifreeze must be used and the JW3 jumper on the DXM2.5/CXM2 should be clipped. This is due to the potential of the refrigerant temperature being as low as 32°F (0°C) with 40°F (4.4°C) LWT, which may lead to a nuisance cutout due to the activation of the Low Temperature Protection. JW3 should never be clipped for standard range equipment or systems without antifreeze.

Performance Data SC*030 (EC Blower Motor)

Models:
SC
006-060

1,000 CFM Rated Airflow

EWT °F	WPD			COOLING - EAT 80/67°F					WPD			Heating - EAT 70°F			
	FLOW GPM	PSI	FT	TC	SC	kW	HR	EER	FLOW GPM	PSI	FT	HC	kW	COP	HE
20	Operation Not Recommended								7.5	6.6	15.3	19.9	1.9	3.0	13.3
30	3.8	2.0	4.6	33.5	23.1	1.2	37.7	27.3	3.8	2.0	4.6	21.8	2.0	3.3	15.1
	5.6	3.7	8.5	33.4	23.0	1.2	37.4	29.0	5.6	3.7	8.5	22.6	2.0	3.3	15.9
	7.5	5.3	12.3	33.3	22.9	1.1	37.1	29.8	7.5	5.3	12.3	23.1	2.0	3.4	16.3
40	3.8	1.6	3.6	33.2	23.0	1.4	37.9	24.5	3.8	1.6	3.6	24.8	2.0	3.6	17.9
	5.6	2.9	6.7	33.5	23.1	1.3	37.8	26.3	5.6	2.9	6.7	25.7	2.0	3.7	18.7
	7.5	4.4	10.1	33.5	23.1	1.2	37.7	27.3	7.5	4.4	10.1	26.3	2.1	3.7	19.2
50	3.8	1.3	3.0	32.5	22.8	1.5	37.6	21.5	3.8	1.3	3.0	27.7	2.1	3.9	20.6
	5.6	2.4	5.5	33.0	23.0	1.4	37.8	23.4	5.6	2.4	5.5	28.8	2.1	4.0	21.6
	7.5	3.8	8.7	33.2	23.0	1.4	37.9	24.4	7.5	3.8	8.7	29.4	2.1	4.1	22.2
60	3.8	1.1	2.5	31.4	22.5	1.7	37.1	18.6	3.8	1.1	2.5	30.6	2.1	4.2	23.3
	5.6	2.1	4.8	32.1	22.7	1.6	37.5	20.4	5.6	2.1	4.8	31.8	2.2	4.3	24.4
	7.5	3.4	7.8	32.5	22.8	1.5	37.6	21.4	7.5	3.4	7.8	32.5	2.2	4.4	25.1
70	3.8	1.0	2.3	30.0	22.0	1.9	36.4	15.8	3.8	1.0	2.3	33.5	2.2	4.5	26.0
	5.6	1.9	4.4	30.9	22.3	1.8	36.9	17.5	5.6	1.9	4.4	34.9	2.2	4.6	27.3
	7.5	3.2	7.3	31.3	22.5	1.7	37.1	18.5	7.5	3.2	7.3	35.7	2.3	4.6	28.0
80	3.8	1.0	2.2	28.4	21.4	2.1	35.6	13.3	3.8	1.0	2.2	36.5	2.3	4.7	28.7
	5.6	1.9	4.3	29.4	21.8	2.0	36.1	14.8	5.6	1.9	4.3	38.0	2.3	4.8	30.1
	7.5	3.1	7.1	29.9	22.0	1.9	36.4	15.7	7.5	3.1	7.1	38.8	2.3	4.9	30.9
90	3.8	0.9	2.1	26.6	20.7	2.4	34.8	11.1	3.8	0.9	2.1	39.4	2.3	5.0	31.4
	5.6	1.8	4.2	27.7	21.2	2.2	35.3	12.4	5.6	1.8	4.2	41.1	2.4	5.1	33.0
	7.5	3.0	7.0	28.2	21.4	2.1	35.6	13.2	7.5	3.0	7.0	42.0	2.4	5.2	33.9
100	3.8	0.9	2.0	24.9	20.0	2.7	34.1	9.2	Operation Not Recommended						
	5.6	1.8	4.1	25.9	20.4	2.5	34.5	10.3							
	7.5	3.0	6.9	26.5	20.7	2.4	34.7	10.9							
110	3.8	0.8	1.9	23.1	19.2	3.0	33.5	7.6							
	5.6	1.7	3.8	24.1	19.6	2.8	33.8	8.5							
	7.5	2.8	6.5	24.7	19.9	2.7	34.0	9.0							
120	3.8	0.7	1.5	21.5	18.3	3.4	33.2	6.2							
	5.6	1.4	3.3	22.4	18.8	3.2	33.4	7.0							
	7.5	2.5	5.8	22.9	19.1	3.1	33.5	7.4							

Notes:

- Interpolation is permissible; extrapolation is not.
- All entering air conditions are 80°F (26.6°C) DB and 67°F (19.4°C) WB in cooling, and 70°F (21°C) DB in heating.
- Table does not reflect fan or pump power corrections for AHRI/ISO conditions.
- All performance is based upon the lower voltage of dual voltage rated units.
- Performance stated is at the rated power supply; performance may vary as the power supply varies from the rated.
- Operation below 40°F (4.4°C) is based upon 20% methanol antifreeze solution.
- Operation below 60°F (15.5°C) EWT requires optional insulated water/refrigerant circuit.
- See performance correction tables for operating conditions other than those listed above.
- See Performance Data Selection Notes for operation in the shaded areas.
- Performance capacities shown in thousands of Btu/h.
- For unit operation in the shaded area when LWT is below 40°F (4.4°C), antifreeze must be used and the JW3 jumper on the DXM2.5/CXM2 should be clipped. This is due to the potential of the refrigerant temperature being as low as 32°F (0°C) with 40°F (4.4°C) LWT, which may lead to a nuisance cutout due to the activation of the Low Temperature Protection. JW3 should never be clipped for standard range equipment or systems without antifreeze.

Performance Data SC*036 (PSC Blower Motor)

Models:
SC
006-060

1,150 CFM Rated Airflow

EWT °F	WPD			COOLING - EAT 80/67°F					WPD			Heating - EAT 70°F			
	FLOW GPM	PSI	FT	TC	SC	kW	HR	EER	FLOW GPM	PSI	FT	HC	kW	COP	HE
20	Operation Not Recommended								9.0	5.1	11.7	24.6	2.4	3.0	16.4
30	3.0	0.9	2.0	38.7	27.4	1.6	44.0	24.9	4.5	1.6	3.8	25.6	2.4	3.1	17.3
	6.0	2.4	5.5	38.0	26.0	1.3	42.4	29.3	6.0	2.4	5.5	27.9	2.5	3.3	19.5
	9.0	4.1	9.5	37.3	25.3	1.2	41.5	30.4	9.0	4.1	9.5	28.9	2.5	3.4	20.4
40	3.0	0.6	1.5	38.3	27.7	1.8	44.3	21.7	4.5	1.3	3.0	29.2	2.5	3.4	20.7
	6.0	1.9	4.3	38.7	27.1	1.5	43.7	26.4	6.0	1.9	4.3	32.1	2.6	3.6	23.3
	9.0	3.4	7.8	38.5	26.7	1.4	43.2	27.9	9.0	3.4	7.8	33.2	2.6	3.7	24.3
50	3.0	0.5	1.2	37.3	27.5	2.0	44.1	18.7	4.5	1.0	2.4	32.9	2.6	3.7	24.0
	6.0	1.5	3.5	38.6	27.6	1.7	44.3	23.2	6.0	1.5	3.5	36.2	2.7	4.0	27.1
	9.0	2.9	6.7	38.7	27.5	1.6	44.1	24.8	9.0	2.9	6.7	37.5	2.7	4.0	28.2
60	3.0	0.4	1.0	35.9	27.0	2.2	43.6	16.0	4.5	0.9	2.1	36.6	2.7	4.0	27.4
	6.0	1.3	3.1	37.8	27.7	1.9	44.3	20.1	6.0	1.3	3.1	40.3	2.8	4.2	30.8
	9.0	2.6	6.0	38.3	27.7	1.8	44.3	21.6	9.0	2.6	6.0	41.8	2.8	4.3	32.1
70	3.0	0.4	0.9	34.3	26.3	2.5	42.8	13.6	4.5	0.8	2.0	40.2	2.8	4.2	30.7
	6.0	1.2	2.9	36.6	27.3	2.1	43.9	17.2	6.0	1.2	2.9	44.4	2.9	4.5	34.5
	9.0	2.4	5.6	37.3	27.5	2.0	44.1	18.6	9.0	2.4	5.6	46.0	2.9	4.6	35.9
80	3.0	0.4	0.9	32.4	25.4	2.8	42.0	11.6	4.5	0.8	1.9	43.8	2.9	4.5	34.0
	6.0	1.2	2.8	35.0	26.6	2.4	43.2	14.6	6.0	1.2	2.8	48.3	3.0	4.7	38.0
	9.0	2.4	5.5	35.8	27.0	2.3	43.5	15.8	9.0	2.4	5.5	50.0	3.1	4.8	39.6
90	3.0	0.4	0.9	30.5	24.5	3.1	41.2	9.8	4.5	0.8	1.9	47.4	3.0	4.6	37.2
	6.0	1.2	2.8	33.2	25.8	2.7	42.3	12.4	6.0	1.2	2.8	52.2	3.1	4.9	41.5
	9.0	2.3	5.4	34.1	26.2	2.5	42.7	13.4	9.0	2.3	5.4	54.0	3.2	5.0	43.1
100	3.0	0.4	0.9	28.7	23.6	3.4	40.4	8.3	Operation Not Recommended						
	6.0	1.2	2.8	31.3	24.9	3.0	41.5	10.5							
	9.0	2.3	5.3	32.2	25.3	2.8	41.9	11.3							
110	3.0	0.4	0.9	27.0	22.9	3.8	40.0	7.1							
	6.0	1.1	2.6	29.3	23.9	3.3	40.7	8.8							
	9.0	2.2	5.2	30.2	24.4	3.2	41.0	9.5							
120	3.0	0.3	0.7	25.6	22.4	4.2	39.9	6.1							
	6.0	1.0	2.3	27.5	23.1	3.7	40.1	7.5							
	9.0	2.1	4.7	28.3	23.5	3.5	40.3	8.1							

Notes:

- Interpolation is permissible; extrapolation is not.
- All entering air conditions are 80°F (26.6°C) DB and 67°F (19.4°C) WB in cooling, and 70°F (21°C) DB in heating.
- Table does not reflect fan or pump power corrections for AHRI/ISO conditions.
- All performance is based upon the lower voltage of dual voltage rated units.
- Performance stated is at the rated power supply; performance may vary as the power supply varies from the rated.
- Operation below 40°F (4.4°C) is based upon 20% methanol antifreeze solution.
- Operation below 60°F (15.5°C) EWT requires optional insulated water/refrigerant circuit.
- See performance correction tables for operating conditions other than those listed above.
- See Performance Data Selection Notes for operation in the shaded areas.
- Performance capacities shown in thousands of Btu/h.
- For unit operation in the shaded area when LWT is below 40°F (4.4°C), antifreeze must be used and the JW3 jumper on the DXM2.5/CXM2 should be clipped. This is due to the potential of the refrigerant temperature being as low as 32°F (0°C) with 40°F (4.4°C) LWT, which may lead to a nuisance cutout due to the activation of the Low Temperature Protection. JW3 should never be clipped for standard range equipment or systems without antifreeze.

Performance Data SC*036 (EC Blower Motor)

Models:
SC
006-060

1,150 CFM Rated Airflow

EWT °F	WPD			COOLING - EAT 80/67°F					WPD			Heating - EAT 70°F			
	FLOW GPM	PSI	FT	TC	SC	kW	HR	EER	FLOW GPM	PSI	FT	HC	kW	COP	HE
20	Operation Not Recommended								9.0	5.1	11.7	24.5	2.3	3.1	16.5
30	3.0	0.9	2.0	38.7	27.4	1.5	43.9	25.6	4.5	1.6	3.8	25.5	2.4	3.1	17.4
	6.0	2.4	5.5	38.0	26.0	1.3	42.2	30.2	6.0	2.4	5.5	27.9	2.4	3.4	19.6
	9.0	4.1	9.5	37.3	25.3	1.2	41.3	31.4	9.0	4.1	9.5	28.8	2.5	3.4	20.4
40	3.0	0.6	1.5	38.3	27.7	1.7	44.2	22.2	4.5	1.3	3.0	29.1	2.5	3.5	20.7
	6.0	1.9	4.3	38.7	27.1	1.4	43.6	27.1	6.0	1.9	4.3	32.0	2.5	3.7	23.3
	9.0	3.4	7.8	38.5	26.7	1.3	43.0	28.7	9.0	3.4	7.8	33.1	2.6	3.8	24.3
50	3.0	0.5	1.2	37.3	27.5	2.0	44.0	19.1	4.5	1.0	2.4	32.8	2.6	3.8	24.1
	6.0	1.5	3.5	38.6	27.6	1.6	44.1	23.8	6.0	1.5	3.5	36.1	2.6	4.0	27.1
	9.0	2.9	6.7	38.7	27.5	1.5	43.9	25.4	9.0	2.9	6.7	37.4	2.7	4.1	28.3
60	3.0	0.4	1.0	35.9	27.0	2.2	43.4	16.3	4.5	0.9	2.1	36.5	2.7	4.0	27.4
	6.0	1.3	3.1	37.8	27.7	1.8	44.1	20.5	6.0	1.3	3.1	40.2	2.8	4.3	30.8
	9.0	2.6	6.0	38.3	27.7	1.7	44.2	22.1	9.0	2.6	6.0	41.7	2.8	4.4	32.1
70	3.0	0.4	0.9	34.3	26.3	2.5	42.7	13.9	4.5	0.8	2.0	40.1	2.7	4.3	30.7
	6.0	1.2	2.9	36.6	27.3	2.1	43.7	17.6	6.0	1.2	2.9	44.2	2.9	4.5	34.5
	9.0	2.4	5.6	37.3	27.5	2.0	44.0	19.0	9.0	2.4	5.6	45.8	2.9	4.6	35.9
80	3.0	0.4	0.9	32.4	25.4	2.8	41.9	11.7	4.5	0.8	1.9	43.7	2.8	4.5	34.0
	6.0	1.2	2.8	35.0	26.6	2.4	43.0	14.9	6.0	1.2	2.8	48.2	3.0	4.7	38.0
	9.0	2.4	5.5	35.8	27.0	2.2	43.4	16.1	9.0	2.4	5.5	49.9	3.0	4.8	39.6
90	3.0	0.4	0.9	30.6	24.5	3.1	41.0	9.9	4.5	0.8	1.9	47.3	2.9	4.7	37.2
	6.0	1.2	2.8	33.2	25.8	2.6	42.2	12.6	6.0	1.2	2.8	52.0	3.1	4.9	41.5
	9.0	2.3	5.4	34.1	26.2	2.5	42.6	13.6	9.0	2.3	5.4	53.8	3.2	5.0	43.0
100	3.0	0.4	0.9	28.7	23.7	3.4	40.3	8.4	Operation Not Recommended						
	6.0	1.2	2.8	31.3	24.9	3.0	41.3	10.6							
	9.0	2.3	5.3	32.2	25.3	2.8	41.7	11.5							
110	3.0	0.4	0.9	27.0	22.9	3.8	39.9	7.2							
	6.0	1.1	2.6	29.4	24.0	3.3	40.6	8.9							
	9.0	2.2	5.2	30.2	24.4	3.1	40.9	9.7							
120	3.0	0.3	0.7	25.6	22.4	4.1	39.8	6.2							
	6.0	1.0	2.3	27.6	23.1	3.6	40.0	7.6							
	9.0	2.1	4.7	28.3	23.5	3.5	40.2	8.1							

Notes:

- Interpolation is permissible; extrapolation is not.
- All entering air conditions are 80°F (26.6°C) DB and 67°F (19.4°C) WB in cooling, and 70°F (21°C) DB in heating.
- Table does not reflect fan or pump power corrections for AHRI/ISO conditions.
- All performance is based upon the lower voltage of dual voltage rated units.
- Performance stated is at the rated power supply; performance may vary as the power supply varies from the rated.
- Operation below 40°F (4.4°C) is based upon 20% methanol antifreeze solution.
- Operation below 60°F (15.5°C) EWT requires optional insulated water/refrigerant circuit.
- See performance correction tables for operating conditions other than those listed above.
- See Performance Data Selection Notes for operation in the shaded areas.
- Performance capacities shown in thousands of Btu/h.
- For unit operation in the shaded area when LWT is below 40°F (4.4°C), antifreeze must be used and the JW3 jumper on the DXM2.5/CXM2 should be clipped. This is due to the potential of the refrigerant temperature being as low as 32°F (0°C) with 40°F (4.4°C) LWT, which may lead to a nuisance cutout due to the activation of the Low Temperature Protection. JW3 should never be clipped for standard range equipment or systems without antifreeze.

Performance Data SC041 (PSC Blower Motor)

Models:
SC
006-060

1,100 CFM Rated Airflow

EWT °F	WPD			COOLING - EAT 80/67°F					WPD			Heating - EAT 70°F			
	FLOW GPM	PSI	FT	TC	SC	kW	HR	EER	FLOW GPM	PSI	FT	HC	kW	COP	HE
20	Operation Not Recommended								10.0	4.2	9.7	23.7	2.5	2.7	15.0
30	5.0	1.3	3.0	44.9	26.7	1.4	49.7	31.7	5.0	1.3	3.1	26.2	2.5	3.0	17.5
	7.5	2.4	5.6	45.0	26.7	1.3	49.6	33.8	7.5	2.6	6.1	27.0	2.6	3.1	18.3
	10.0	3.5	8.1	45.2	26.7	1.3	49.5	36.1	10.0	4.0	9.2	27.9	2.6	3.2	19.1
40	5.0	1.1	2.5	42.9	27.1	1.7	48.6	25.8	5.0	1.0	2.4	32.4	2.6	3.6	23.4
	7.5	2.2	5.0	43.1	27.1	1.6	48.5	27.2	7.5	2.4	5.5	33.3	2.6	3.7	24.2
	10.0	3.2	7.5	43.3	27.1	1.5	48.4	28.8	10.0	3.7	8.5	34.1	2.7	3.8	25.1
50	5.0	0.8	1.9	42.3	27.1	1.8	48.3	24.2	5.0	0.8	1.8	34.5	2.7	3.8	25.4
	7.5	1.8	4.1	42.5	27.1	1.7	48.2	25.5	7.5	1.8	4.2	35.3	2.7	3.9	26.2
	10.0	2.7	6.2	42.7	27.1	1.6	48.1	26.9	10.0	2.9	6.7	36.2	2.7	3.9	27.0
60	5.0	0.7	1.7	41.1	27.0	1.9	47.7	21.3	5.0	0.7	1.5	38.6	2.8	4.1	29.2
	7.5	1.7	3.8	41.2	27.0	1.9	47.5	22.3	7.5	1.7	4.0	39.5	2.8	4.2	30.0
	10.0	2.6	6.0	41.4	27.0	1.8	47.4	23.4	10.0	2.8	6.4	40.4	2.8	4.2	30.8
70	5.0	0.6	1.5	39.7	26.7	2.2	47.0	18.4	5.0	0.6	1.3	42.8	2.9	4.3	32.9
	7.5	1.6	3.6	39.9	26.7	2.1	46.9	19.2	7.5	1.6	3.7	43.7	2.9	4.4	33.7
	10.0	2.5	5.7	40.0	26.7	2.0	46.8	20.1	10.0	2.7	6.2	44.5	2.9	4.4	34.5
80	5.0	0.5	1.3	38.1	26.1	2.4	46.5	15.6	5.0	0.4	1.0	47.0	3.1	4.5	36.5
	7.5	1.5	3.4	38.3	26.1	2.4	46.4	16.2	7.5	1.5	3.4	47.9	3.1	4.5	37.3
	10.0	2.4	5.5	38.5	26.1	2.3	46.3	16.9	10.0	2.5	5.9	48.7	3.1	4.6	38.1
90	5.0	0.5	1.1	36.3	25.2	2.8	46.0	12.9	5.0	0.3	0.6	51.2	3.3	4.6	40.0
	7.5	1.4	3.2	36.5	25.2	2.7	45.9	13.3	7.5	1.3	3.1	52.1	3.3	4.6	40.9
	10.0	2.3	5.4	36.7	25.2	2.7	45.8	13.8	10.0	2.4	5.5	53.0	3.3	4.7	41.7
100	5.0	0.4	0.9	34.2	24.1	3.3	45.5	10.3	Operation Not Recommended						
	7.5	1.3	3.1	34.3	24.1	3.2	45.4	10.6							
	10.0	2.2	5.2	34.5	24.1	3.2	45.3	10.9							
110	5.0	0.3	0.8	31.6	22.6	4.0	45.1	8.0							
	7.5	1.3	2.9	31.8	22.6	3.9	45.0	8.2							
	10.0	2.2	5.0	31.9	22.6	3.8	44.9	8.4							
120	5.0	0.3	0.6	28.5	20.8	4.8	44.8	6.0							
	7.5	1.2	2.7	28.7	20.8	4.7	44.7	6.1							
	10.0	2.1	4.9	28.8	20.9	4.6	44.6	6.3							

Notes:

- Interpolation is permissible; extrapolation is not.
- All entering air conditions are 80°F (26.6°C) DB and 67°F (19.4°C) WB in cooling, and 70°F (21°C) DB in heating.
- Table does not reflect fan or pump power corrections for AHRI/ISO conditions.
- All performance is based upon the lower voltage of dual voltage rated units.
- Performance stated is at the rated power supply; performance may vary as the power supply varies from the rated.
- Operation below 40°F (4.4°C) is based upon 20% methanol antifreeze solution.
- Operation below 60°F (15.5°C) EWT requires optional insulated water/refrigerant circuit.
- See performance correction tables for operating conditions other than those listed above.
- See Performance Data Selection Notes for operation in the shaded areas.
- Performance capacities shown in thousands of Btu/h.
- For unit operation in the shaded area when LWT is below 40°F (4.4°C), antifreeze must be used and the JW3 jumper on the DXM2.5/CXM2 should be clipped. This is due to the potential of the refrigerant temperature being as low as 32°F (0°C) with 40°F (4.4°C) LWT, which may lead to a nuisance cutout due to the activation of the Low Temperature Protection. JW3 should never be clipped for standard range equipment or systems without antifreeze.

Performance Data SC*042 (PSC Blower Motor)

Models:
SC
006-060

1,350 CFM Rated Airflow

EWT °F	WPD			COOLING - EAT 80/67°F					WPD			Heating - EAT 70°F			
	FLOW GPM	PSI	FT	TC	SC	kW	HR	EER	FLOW GPM	PSI	FT	HC	kW	COP	HE
20	Operation Not Recommended								10.5	3.9	8.9	28.2	2.8	3.0	18.8
30	5.3	1.2	2.8	43.9	30.4	1.8	50.0	24.2	5.3	1.2	2.8	30.7	2.8	3.2	21.2
	7.9	2.2	5.1	43.0	29.5	1.7	48.9	25.0	7.9	2.2	5.1	31.8	2.8	3.3	22.2
	10.5	3.3	7.6	42.5	28.9	1.7	48.2	25.4	10.5	3.3	7.6	32.4	2.8	3.4	22.8
40	5.3	0.9	2.2	44.4	31.3	2.0	51.2	22.3	5.3	0.9	2.2	34.8	2.9	3.5	25.0
	7.9	1.8	4.2	44.2	30.8	1.9	50.6	23.6	7.9	1.8	4.2	36.1	2.9	3.7	26.2
	10.5	2.8	6.5	43.9	30.5	1.8	50.1	24.1	10.5	2.8	6.5	36.9	2.9	3.7	26.9
50	5.3	0.8	1.7	44.1	31.6	2.2	51.6	20.1	5.3	0.8	1.7	39.0	3.0	3.9	28.9
	7.9	1.6	3.6	44.4	31.5	2.1	51.4	21.5	7.9	1.6	3.6	40.6	3.0	4.0	30.3
	10.5	2.5	5.9	44.4	31.3	2.0	51.2	22.2	10.5	2.5	5.9	41.4	3.0	4.0	31.2
60	5.3	0.7	1.5	43.2	31.4	2.4	51.6	17.7	5.3	0.7	1.5	43.2	3.1	4.1	32.8
	7.9	1.4	3.2	43.9	31.5	2.3	51.7	19.2	7.9	1.4	3.2	45.0	3.1	4.3	34.5
	10.5	2.3	5.4	44.1	31.6	2.2	51.6	20.0	10.5	2.3	5.4	46.0	3.1	4.3	35.4
70	5.3	0.6	1.4	41.9	30.8	2.7	51.2	15.3	5.3	0.6	1.4	47.5	3.2	4.4	36.7
	7.9	1.3	3.1	42.8	31.2	2.5	51.5	16.9	7.9	1.3	3.1	49.4	3.2	4.5	38.5
	10.5	2.2	5.2	43.2	31.3	2.5	51.6	17.6	10.5	2.2	5.2	50.5	3.2	4.6	39.5
80	5.3	0.6	1.4	40.1	30.0	3.1	50.5	13.1	5.3	0.6	1.4	51.6	3.3	4.6	40.5
	7.9	1.3	3.0	41.2	30.5	2.8	50.9	14.5	7.9	1.3	3.0	53.7	3.3	4.8	42.4
	10.5	2.2	5.0	41.8	30.8	2.7	51.1	15.2	10.5	2.2	5.0	54.8	3.3	4.8	43.4
90	5.3	0.6	1.5	38.0	29.1	3.4	49.8	11.0	5.3	0.6	1.5	55.6	3.4	4.9	44.1
	7.9	1.3	3.0	39.3	29.6	3.2	50.3	12.3	7.9	1.3	3.0	57.7	3.4	5.0	46.1
	10.5	2.2	5.0	40.0	29.9	3.1	50.5	13.0	10.5	2.2	5.0	58.8	3.4	5.0	47.1
100	5.3	0.6	1.5	35.8	28.1	3.9	49.1	9.2	Operation Not Recommended						
	7.9	1.3	3.0	37.2	28.7	3.6	49.5	10.3							
	10.5	2.1	4.9	37.9	29.0	3.5	49.7	10.9							
110	5.3	0.6	1.4	33.5	27.2	4.4	48.5	7.6							
	7.9	1.3	2.9	34.9	27.7	4.1	48.8	8.5							
	10.5	2.1	4.8	35.6	28.0	3.9	49.0	9.0							
120	5.3	0.6	1.3	31.2	26.3	5.0	48.2	6.2							
	7.9	1.2	2.7	32.6	26.8	4.6	48.4	7.0							
	10.5	2.0	4.6	33.3	27.1	4.5	48.5	7.5							

Notes:

- Interpolation is permissible; extrapolation is not.
- All entering air conditions are 80°F (26.6°C) DB and 67°F (19.4°C) WB in cooling, and 70°F (21°C) DB in heating.
- Table does not reflect fan or pump power corrections for AHRI/ISO conditions.
- All performance is based upon the lower voltage of dual voltage rated units.
- Performance stated is at the rated power supply; performance may vary as the power supply varies from the rated.
- Operation below 40°F (4.4°C) is based upon 20% methanol antifreeze solution.
- Operation below 60°F (15.5°C) EWT requires optional insulated water/refrigerant circuit.
- See performance correction tables for operating conditions other than those listed above.
- See Performance Data Selection Notes for operation in the shaded areas.
- Performance capacities shown in thousands of Btu/h.
- For unit operation in the shaded area when LWT is below 40°F (4.4°C), antifreeze must be used and the JW3 jumper on the DXM2.5/CXM2 should be clipped. This is due to the potential of the refrigerant temperature being as low as 32°F (0°C) with 40°F (4.4°C) LWT, which may lead to a nuisance cutout due to the activation of the Low Temperature Protection. JW3 should never be clipped for standard range equipment or systems without antifreeze.

Performance Data SC*042 (EC Blower Motor)

Models:
SC
006-060

1,350 CFM Rated Airflow

EWT °F	WPD			COOLING - EAT 80/67°F					WPD			Heating - EAT 70°F			
	FLOW GPM	PSI	FT	TC	SC	kW	HR	EER	FLOW GPM	PSI	FT	HC	kW	COP	HE
20	Operation Not Recommended								10.5	3.9	8.9	27.9	2.6	3.1	19.0
30	5.3	1.2	2.8	43.9	30.4	1.7	49.5	26.5	5.3	1.2	2.8	30.4	2.6	3.4	21.4
	7.9	2.2	5.1	43.1	29.5	1.6	48.4	27.6	7.9	2.2	5.1	31.5	2.7	3.5	22.4
	10.5	3.3	7.6	42.6	28.9	1.5	47.7	28.0	10.5	3.3	7.6	32.1	2.7	3.5	23.0
40	5.3	0.9	2.2	44.4	31.3	1.8	50.7	24.3	5.3	0.9	2.2	34.4	2.7	3.7	25.2
	7.9	1.8	4.2	44.2	30.9	1.7	50.1	25.8	7.9	1.8	4.2	35.8	2.7	3.8	26.4
	10.5	2.8	6.5	44.0	30.5	1.7	49.6	26.4	10.5	2.8	6.5	36.5	2.8	3.9	27.1
50	5.3	0.8	1.7	44.2	31.6	2.0	51.1	21.7	5.3	0.8	1.7	38.6	2.8	4.0	29.0
	7.9	1.6	3.6	44.4	31.5	1.9	50.9	23.4	7.9	1.6	3.6	40.2	2.8	4.2	30.5
	10.5	2.5	5.9	44.4	31.4	1.8	50.7	24.2	10.5	2.5	5.9	41.0	2.9	4.2	31.3
60	5.3	0.7	1.5	43.3	31.4	2.3	51.1	19.0	5.3	0.7	1.5	42.8	2.9	4.3	32.9
	7.9	1.4	3.2	43.9	31.6	2.1	51.1	20.7	7.9	1.4	3.2	44.6	2.9	4.4	34.6
	10.5	2.3	5.4	44.1	31.6	2.0	51.1	21.6	10.5	2.3	5.4	45.6	3.0	4.5	35.5
70	5.3	0.6	1.4	41.9	30.8	2.6	50.6	16.3	5.3	0.6	1.4	47.0	3.0	4.6	36.8
	7.9	1.3	3.1	42.8	31.2	2.4	50.9	18.0	7.9	1.3	3.1	49.0	3.0	4.7	38.6
	10.5	2.2	5.2	43.2	31.4	2.3	51.1	18.9	10.5	2.2	5.2	50.0	3.1	4.8	39.5
80	5.3	0.6	1.4	40.1	30.0	2.9	50.0	13.8	5.3	0.6	1.4	51.1	3.1	4.8	40.5
	7.9	1.3	3.0	41.3	30.5	2.7	50.4	15.4	7.9	1.3	3.0	53.2	3.2	4.9	42.4
	10.5	2.2	5.0	41.8	30.8	2.6	50.6	16.2	10.5	2.2	5.0	54.3	3.2	5.0	43.4
90	5.3	0.6	1.5	38.1	29.1	3.3	49.3	11.6	5.3	0.6	1.5	55.0	3.2	5.0	44.1
	7.9	1.3	3.0	39.4	29.7	3.0	49.8	12.9	7.9	1.3	3.0	57.1	3.2	5.2	46.0
	10.5	2.2	5.0	40.0	30.0	2.9	50.0	13.7	10.5	2.2	5.0	58.2	3.3	5.2	47.1
100	5.3	0.6	1.5	35.9	28.1	3.7	48.6	9.6	Operation Not Recommended						
	7.9	1.3	3.0	37.2	28.7	3.5	49.0	10.8							
	10.5	2.1	4.9	37.9	29.0	3.3	49.2	11.4							
110	5.3	0.6	1.4	33.5	27.2	4.3	48.0	7.9							
	7.9	1.3	2.9	34.9	27.8	3.9	48.4	8.9							
	10.5	2.1	4.8	35.7	28.0	3.8	48.5	9.4							
120	5.3	0.6	1.3	31.2	26.4	4.8	47.8	6.4							
	7.9	1.2	2.7	32.6	26.9	4.5	47.9	7.3							
	10.5	2.0	4.6	33.3	27.1	4.3	48.0	7.7							

Notes:

- Interpolation is permissible; extrapolation is not.
- All entering air conditions are 80°F (26.6°C) DB and 67°F (19.4°C) WB in cooling, and 70°F (21°C) DB in heating.
- Table does not reflect fan or pump power corrections for AHRI/ISO conditions.
- All performance is based upon the lower voltage of dual voltage rated units.
- Performance stated is at the rated power supply; performance may vary as the power supply varies from the rated.
- Operation below 40°F (4.4°C) is based upon 20% methanol antifreeze solution.
- Operation below 60°F (15.5°C) EWT requires optional insulated water/refrigerant circuit.
- See performance correction tables for operating conditions other than those listed above.
- See Performance Data Selection Notes for operation in the shaded areas.
- Performance capacities shown in thousands of Btu/h.
- For unit operation in the shaded area when LWT is below 40°F (4.4°C), antifreeze must be used and the JW3 jumper on the DXM2.5/CXM2 should be clipped. This is due to the potential of the refrigerant temperature being as low as 32°F (0°C) with 40°F (4.4°C) LWT, which may lead to a nuisance cutout due to the activation of the Low Temperature Protection. JW3 should never be clipped for standard range equipment or systems without antifreeze.

Performance Data SC*048 (PSC Blower Motor)

Models:
SC
006-060

1,550 CFM Rated Airflow

EWT °F	WPD			COOLING - EAT 80/67°F					WPD			Heating - EAT 70°F			
	FLOW GPM	PSI	FT	TC	SC	kW	HR	EER	FLOW GPM	PSI	FT	HC	kW	COP	HE
20	Operation Not Recommended								12.0	6.9	15.8	33.3	3.4	2.9	21.8
	6.0	1.9	4.3	55.4	36.5	2.2	62.8	25.7	6.0	1.9	4.3	36.1	3.4	3.1	24.3
30	9.0	3.8	8.9	55.7	36.5	2.0	62.7	27.4	9.0	3.8	8.9	37.4	3.5	3.2	25.5
	12.0	6.2	14.3	55.8	36.4	2.0	62.5	28.3	12.0	6.2	14.3	38.1	3.5	3.2	26.2
40	6.0	1.7	3.9	54.6	36.3	2.4	62.7	23.1	6.0	1.7	3.9	40.8	3.5	3.4	28.8
	9.0	3.5	8.0	55.2	36.5	2.2	62.8	24.9	9.0	3.5	8.0	42.5	3.6	3.5	30.3
50	12.0	5.7	13.2	55.5	36.5	2.1	62.8	25.8	12.0	5.7	13.2	43.4	3.6	3.6	31.2
	6.0	1.6	3.6	53.4	35.9	2.6	62.3	20.5	6.0	1.6	3.6	45.9	3.6	3.7	33.5
60	9.0	3.2	7.5	54.3	36.2	2.4	62.6	22.3	9.0	3.2	7.5	48.0	3.7	3.8	35.5
	12.0	5.4	12.4	54.7	36.3	2.4	62.7	23.2	12.0	5.4	12.4	49.2	3.7	3.9	36.6
70	6.0	1.5	3.4	51.9	35.3	2.9	61.7	18.0	6.0	1.5	3.4	51.3	3.7	4.0	38.5
	9.0	3.1	7.1	53.0	35.7	2.7	62.1	19.8	9.0	3.1	7.1	53.8	3.8	4.2	40.8
80	12.0	5.2	11.9	53.5	35.9	2.6	62.3	20.6	12.0	5.2	11.9	55.1	3.8	4.2	42.1
	6.0	1.4	3.3	50.1	34.5	3.2	61.0	15.6	6.0	1.4	3.3	56.7	3.9	4.3	43.6
90	9.0	3.0	6.8	51.4	35.1	3.0	61.5	17.2	9.0	3.0	6.8	59.5	3.9	4.4	46.1
	12.0	5.0	11.6	52.0	35.3	2.9	61.8	18.1	12.0	5.0	11.6	61.0	4.0	4.5	47.5
100	6.0	1.4	3.2	48.0	33.7	3.6	60.2	13.3	6.0	1.4	3.2	62.1	4.0	4.6	48.5
	9.0	2.9	6.7	49.4	34.3	3.3	60.8	14.8	9.0	2.9	6.7	65.1	4.0	4.7	51.3
110	12.0	4.9	11.4	50.1	34.6	3.2	61.0	15.6	12.0	4.9	11.4	66.7	4.1	4.8	52.8
	6.0	1.4	3.2	45.6	32.6	4.1	59.4	11.3	6.0	1.4	3.2	67.3	4.1	4.8	53.3
120	9.0	2.9	6.6	47.2	33.3	3.7	60.0	12.6	9.0	2.9	6.6	70.4	4.2	4.9	56.2
	12.0	4.9	11.3	48.0	33.7	3.6	60.2	13.3	12.0	4.9	11.3	72.0	4.2	5.0	57.6
130	6.0	1.3	3.1	43.1	31.5	4.6	58.7	9.4	Operation Not Recommended						
	9.0	2.8	6.5	44.8	32.3	4.2	59.2	10.6							
140	12.0	4.8	11.2	45.6	32.6	4.1	59.4	11.2	Operation Not Recommended						
	6.0	1.3	3.0	40.3	30.3	5.2	58.1	7.7							
150	9.0	2.8	6.4	42.1	31.1	4.8	58.5	8.8	Operation Not Recommended						
	12.0	4.7	11.0	43.0	31.5	4.6	58.7	9.3							
160	6.0	1.2	2.9	37.4	29.0	5.9	57.6	6.3	Operation Not Recommended						
	9.0	2.7	6.1	39.3	29.9	5.5	57.9	7.2							
170	12.0	4.6	10.6	40.2	30.3	5.2	58.0	7.7	Operation Not Recommended						

Notes:

- Interpolation is permissible; extrapolation is not.
- All entering air conditions are 80°F (26.6°C) DB and 67°F (19.4°C) WB in cooling, and 70°F (21°C) DB in heating.
- Table does not reflect fan or pump power corrections for AHRI/ISO conditions.
- All performance is based upon the lower voltage of dual voltage rated units.
- Performance stated is at the rated power supply; performance may vary as the power supply varies from the rated.
- Operation below 40°F (4.4°C) is based upon 20% methanol antifreeze solution.
- Operation below 60°F (15.5°C) EWT requires optional insulated water/refrigerant circuit.
- See performance correction tables for operating conditions other than those listed above.
- See Performance Data Selection Notes for operation in the shaded areas.
- Performance capacities shown in thousands of Btu/h.
- For unit operation in the shaded area when LWT is below 40°F (4.4°C), antifreeze must be used and the JW3 jumper on the DXM2.5/CXM2 should be clipped. This is due to the potential of the refrigerant temperature being as low as 32°F (0°C) with 40°F (4.4°C) LWT, which may lead to a nuisance cutout due to the activation of the Low Temperature Protection. JW3 should never be clipped for standard range equipment or systems without antifreeze.

Performance Data SC*048 (EC Blower Motor)

Models:
SC
006-060

1,550 CFM Rated Airflow

EWT °F	WPD			COOLING - EAT 80/67°F					WPD			Heating - EAT 70°F			
	FLOW GPM	PSI	FT	TC	SC	kW	HR	EER	FLOW GPM	PSI	FT	HC	kW	COP	HE
20	Operation Not Recommended								12.0	6.9	15.8	33.1	3.3	3.0	21.9
	6.0	1.9	4.3	55.4	36.5	2.1	62.5	26.8	6.0	1.9	4.3	35.8	3.3	3.1	24.4
30	9.0	3.8	8.9	55.7	36.5	1.9	62.4	28.7	9.0	3.8	8.9	37.1	3.4	3.2	25.6
	12.0	6.2	14.3	55.8	36.4	1.9	62.2	29.7	12.0	6.2	14.3	37.8	3.4	3.3	26.3
40	6.0	1.7	3.9	54.6	36.3	2.3	62.4	24.0	6.0	1.7	3.9	40.6	3.4	3.5	28.8
	9.0	3.5	8.0	55.2	36.5	2.1	62.5	26.0	9.0	3.5	8.0	42.3	3.5	3.6	30.4
50	12.0	5.7	13.2	55.4	36.5	2.1	62.5	26.9	12.0	5.7	13.2	43.2	3.5	3.6	31.3
	6.0	1.6	3.6	53.4	35.9	2.5	62.0	21.3	6.0	1.6	3.6	45.7	3.5	3.8	33.6
60	9.0	3.2	7.5	54.3	36.2	2.3	62.3	23.2	9.0	3.2	7.5	47.7	3.6	3.9	35.5
	12.0	5.4	12.4	54.7	36.3	2.3	62.4	24.1	12.0	5.4	12.4	48.9	3.6	4.0	36.6
70	6.0	1.5	3.4	51.9	35.3	2.8	61.4	18.6	6.0	1.5	3.4	51.0	3.7	4.1	38.5
	9.0	3.1	7.1	53.0	35.7	2.6	61.8	20.4	9.0	3.1	7.1	53.4	3.7	4.2	40.8
80	12.0	5.2	11.9	53.5	35.9	2.5	62.0	21.4	12.0	5.2	11.9	54.8	3.7	4.3	42.0
	6.0	1.4	3.3	50.1	34.5	3.1	60.7	16.0	6.0	1.4	3.3	56.4	3.8	4.4	43.5
90	9.0	3.0	6.8	51.4	35.1	2.9	61.2	17.8	9.0	3.0	6.8	59.2	3.8	4.5	46.1
	12.0	5.0	11.6	51.9	35.3	2.8	61.4	18.7	12.0	5.0	11.6	60.6	3.9	4.6	47.5
100	6.0	1.4	3.2	48.0	33.7	3.5	59.9	13.7	6.0	1.4	3.2	61.7	3.9	4.7	48.5
	9.0	2.9	6.7	49.4	34.3	3.2	60.5	15.3	9.0	2.9	6.7	64.7	4.0	4.8	51.2
110	12.0	4.9	11.4	50.1	34.6	3.1	60.7	16.1	12.0	4.9	11.4	66.3	4.0	4.9	52.7
	6.0	1.4	3.2	45.6	32.7	4.0	59.2	11.5	6.0	1.4	3.2	66.9	4.0	4.9	53.2
120	9.0	2.9	6.6	47.2	33.3	3.7	59.7	12.9	9.0	2.9	6.6	70.0	4.1	5.0	56.0
	12.0	4.9	11.3	48.0	33.7	3.5	59.9	13.7	12.0	4.9	11.3	71.6	4.1	5.1	57.5
130	6.0	1.3	3.1	43.1	31.5	4.5	58.4	9.6	Operation Not Recommended						
	9.0	2.8	6.5	44.8	32.3	4.1	58.9	10.8	Operation Not Recommended						
140	12.0	4.8	11.2	45.6	32.6	4.0	59.1	11.5	Operation Not Recommended						
	6.0	1.3	3.0	40.3	30.3	5.1	57.8	7.9	Operation Not Recommended						
150	9.0	2.8	6.4	42.1	31.1	4.7	58.2	9.0	Operation Not Recommended						
	12.0	4.7	11.0	43.0	31.5	4.5	58.4	9.5	Operation Not Recommended						
160	6.0	1.2	2.9	37.4	29.0	5.8	57.3	6.4	Operation Not Recommended						
	9.0	2.7	6.1	39.3	29.9	5.4	57.6	7.3	Operation Not Recommended						
170	12.0	4.6	10.6	40.2	30.3	5.1	57.8	7.8	Operation Not Recommended						

Notes:

- Interpolation is permissible; extrapolation is not.
- All entering air conditions are 80°F (26.6°C) DB and 67°F (19.4°C) WB in cooling, and 70°F (21°C) DB in heating.
- Table does not reflect fan or pump power corrections for AHRI/ISO conditions.
- All performance is based upon the lower voltage of dual voltage rated units.
- Performance stated is at the rated power supply; performance may vary as the power supply varies from the rated.
- Operation below 40°F (4.4°C) is based upon 20% methanol antifreeze solution.
- Operation below 60°F (15.5°C) EWT requires optional insulated water/refrigerant circuit.
- See performance correction tables for operating conditions other than those listed above.
- See Performance Data Selection Notes for operation in the shaded areas.
- Performance capacities shown in thousands of Btu/h.
- For unit operation in the shaded area when LWT is below 40°F (4.4°C), antifreeze must be used and the JW3 jumper on the DXM2.5/CXM2 should be clipped. This is due to the potential of the refrigerant temperature being as low as 32°F (0°C) with 40°F (4.4°C) LWT, which may lead to a nuisance cutout due to the activation of the Low Temperature Protection. JW3 should never be clipped for standard range equipment or systems without antifreeze.

Performance Data SC*060 (PSC Blower Motor)

Models:
SC
006-060

2,000 CFM Rated Airflow

EWT °F	WPD			COOLING - EAT 80/67°F					WPD			Heating - EAT 70°F			
	FLOW GPM	PSI	FT	TC	SC	kW	HR	EER	FLOW GPM	PSI	FT	HC	kW	COP	HE
20	Operation Not Recommended								15.0	9.5	22.0	37.2	4.1	2.6	23.1
	7.5	2.6	6.0	66.6	44.5	2.9	76.6	22.6	7.5	2.6	6.0	41.8	4.2	2.9	27.5
30	11.3	5.3	12.3	65.6	43.3	2.8	75.3	23.2	11.3	5.3	12.3	43.5	4.2	3.0	29.2
	15.0	8.5	19.6	64.9	42.5	2.8	74.4	23.4	15.0	8.5	19.6	44.5	4.2	3.1	30.1
40	7.5	2.3	5.3	66.8	45.5	3.2	77.6	21.1	7.5	2.3	5.3	48.6	4.3	3.3	34.0
	11.3	4.7	10.9	66.8	44.9	3.0	77.0	22.2	11.3	4.7	10.9	50.8	4.3	3.4	36.1
50	15.0	7.7	17.8	66.5	44.5	2.9	76.6	22.6	15.0	7.7	17.8	52.1	4.3	3.5	37.2
	7.5	2.1	4.9	66.0	45.6	3.4	77.7	19.2	7.5	2.1	4.9	55.6	4.4	3.7	40.5
60	11.3	4.3	10.0	66.7	45.6	3.2	77.7	20.6	11.3	4.3	10.0	58.3	4.5	3.8	43.0
	15.0	7.2	16.5	66.8	45.5	3.2	77.6	21.2	15.0	7.2	16.5	59.7	4.5	3.9	44.4
70	7.5	2.0	4.6	64.3	45.2	3.8	77.2	17.1	7.5	2.0	4.6	62.5	4.5	4.0	47.0
	11.3	4.1	9.4	65.6	45.6	3.5	77.6	18.6	11.3	4.1	9.4	65.6	4.6	4.2	49.8
80	15.0	6.8	15.6	66.1	45.7	3.4	77.7	19.3	15.0	6.8	15.6	67.2	4.6	4.2	51.4
	7.5	1.9	4.4	62.0	44.3	4.1	76.2	15.0	7.5	1.9	4.4	69.3	4.7	4.3	53.3
90	11.3	3.9	9.0	63.7	44.9	3.9	76.9	16.4	11.3	3.9	9.0	72.6	4.8	4.5	56.3
	15.0	6.5	15.1	64.4	45.2	3.7	77.2	17.2	15.0	6.5	15.1	74.3	4.8	4.5	57.9
100	7.5	1.9	4.3	59.2	43.1	4.6	74.9	12.9	7.5	1.9	4.3	75.7	4.8	4.6	59.3
	11.3	3.8	8.8	61.2	43.9	4.3	75.8	14.3	11.3	3.8	8.8	79.1	4.9	4.7	62.3
110	15.0	6.4	14.8	62.1	44.3	4.1	76.2	15.0	15.0	6.4	14.8	80.8	4.9	4.8	63.9
	7.5	1.8	4.2	56.1	41.7	5.1	73.5	11.0	7.5	1.8	4.2	81.6	5.0	4.8	64.7
120	11.3	3.8	8.7	58.2	42.6	4.8	74.4	12.2	11.3	3.8	8.7	84.8	5.0	4.9	67.6
	15.0	6.3	14.5	59.2	43.1	4.6	74.9	12.9	15.0	6.3	14.5	86.3	5.1	5.0	69.1
130	7.5	1.8	4.1	52.8	40.3	5.7	72.2	9.3	Operation Not Recommended						
	11.3	3.7	8.5	55.0	41.2	5.3	73.1	10.4							
140	15.0	6.2	14.3	56.1	41.7	5.1	73.5	11.0	Operation Not Recommended						
	7.5	1.7	4.0	49.6	38.9	6.3	71.2	7.8							
150	11.3	3.6	8.2	51.7	39.8	5.9	71.8	8.7	Operation Not Recommended						
	15.0	6.0	13.9	52.7	40.2	5.7	72.2	9.2							
160	7.5	1.6	3.7	46.4	37.8	7.1	70.6	6.5	Operation Not Recommended						
	11.3	3.4	7.8	48.4	38.5	6.6	71.0	7.3							
170	15.0	5.8	13.4	49.4	38.9	6.4	71.2	7.7	Operation Not Recommended						

Notes:

- Interpolation is permissible; extrapolation is not.
- All entering air conditions are 80°F (26.6°C) DB and 67°F (19.4°C) WB in cooling, and 70°F (21°C) DB in heating.
- Table does not reflect fan or pump power corrections for AHRI/ISO conditions.
- All performance is based upon the lower voltage of dual voltage rated units.
- Performance stated is at the rated power supply; performance may vary as the power supply varies from the rated.
- Operation below 40°F (4.4°C) is based upon 20% methanol antifreeze solution.
- Operation below 60°F (15.5°C) EWT requires optional insulated water/refrigerant circuit.
- See performance correction tables for operating conditions other than those listed above.
- See Performance Data Selection Notes for operation in the shaded areas.
- Performance capacities shown in thousands of Btu/h.
- For unit operation in the shaded area when LWT is below 40°F (4.4°C), antifreeze must be used and the JW3 jumper on the DXM2.5/CXM2 should be clipped. This is due to the potential of the refrigerant temperature being as low as 32°F (0°C) with 40°F (4.4°C) LWT, which may lead to a nuisance cutout due to the activation of the Low Temperature Protection. JW3 should never be clipped for standard range equipment or systems without antifreeze.

Performance Data SC*060 (EC Blower Motor)

Models:
SC
006-060

2,000 CFM Rated Airflow

EWT °F	WPD			COOLING - EAT 80/67°F					WPD			Heating - EAT 70°F			
	FLOW GPM	PSI	FT	TC	SC	kW	HR	EER	FLOW GPM	PSI	FT	HC	kW	COP	HE
20	Operation Not Recommended								15.0	9.5	22.0	36.4	3.9	2.7	23.1
	7.5	2.6	6.0	66.6	44.5	2.7	75.8	24.6	7.5	2.6	6.0	41.0	3.9	3.0	27.5
30	11.3	5.3	12.3	65.6	43.3	2.6	74.4	25.4	11.3	5.3	12.3	42.7	4.0	3.2	29.2
	15.0	8.5	19.6	64.9	42.5	2.5	73.6	25.6	15.0	8.5	19.6	43.7	4.0	3.2	30.1
40	7.5	2.3	5.3	66.8	45.5	2.9	76.8	22.9	7.5	2.3	5.3	47.8	4.1	3.5	34.0
	11.3	4.7	10.9	66.8	44.9	2.8	76.2	24.1	11.3	4.7	10.9	50.0	4.1	3.6	36.1
50	15.0	7.7	17.8	66.5	44.5	2.7	75.7	24.7	15.0	7.7	17.8	51.2	4.1	3.7	37.2
	7.5	2.1	4.9	66.0	45.6	3.2	76.9	20.7	7.5	2.1	4.9	54.8	4.2	3.8	40.5
60	11.3	4.3	10.0	66.7	45.6	3.0	76.9	22.2	11.3	4.3	10.0	57.4	4.2	4.0	43.0
	15.0	7.2	16.5	66.8	45.5	2.9	76.8	23.0	15.0	7.2	16.5	58.9	4.3	4.1	44.4
70	7.5	2.0	4.6	64.3	45.2	3.5	76.3	18.3	7.5	2.0	4.6	61.7	4.3	4.2	47.0
	11.3	4.1	9.4	65.6	45.6	3.3	76.8	20.0	11.3	4.1	9.4	64.7	4.4	4.3	49.8
80	15.0	6.8	15.6	66.1	45.7	3.2	76.9	20.8	15.0	6.8	15.6	66.4	4.4	4.4	51.4
	7.5	1.9	4.4	62.0	44.3	3.9	75.3	15.9	7.5	1.9	4.4	68.5	4.4	4.5	53.3
90	11.3	3.9	9.0	63.7	44.9	3.6	76.1	17.5	11.3	3.9	9.0	71.7	4.5	4.7	56.3
	15.0	6.5	15.1	64.4	45.2	3.5	76.4	18.4	15.0	6.5	15.1	73.5	4.6	4.7	57.9
100	7.5	1.9	4.3	59.2	43.1	4.3	74.1	13.6	7.5	1.9	4.3	74.9	4.6	4.8	59.3
	11.3	3.8	8.8	61.2	43.9	4.0	74.9	15.1	11.3	3.8	8.8	78.2	4.7	4.9	62.3
110	15.0	6.4	14.8	62.1	44.3	3.9	75.4	15.9	15.0	6.4	14.8	79.9	4.7	5.0	63.9
	7.5	1.8	4.2	56.1	41.7	4.9	72.7	11.5	7.5	1.8	4.2	80.8	4.7	5.0	64.7
120	11.3	3.8	8.7	58.2	42.6	4.5	73.6	12.9	11.3	3.8	8.7	84.0	4.8	5.1	67.6
	15.0	6.3	14.5	59.2	43.1	4.3	74.1	13.6	15.0	6.3	14.5	85.5	4.8	5.2	69.1
130	7.5	1.8	4.1	52.8	40.3	5.4	71.4	9.7	Operation Not Recommended						
	11.3	3.7	8.5	55.0	41.2	5.1	72.2	10.9							
140	15.0	6.2	14.3	56.1	41.7	4.9	72.7	11.5	Operation Not Recommended						
	7.5	1.7	4.0	49.6	38.9	6.1	70.4	8.1							
150	11.3	3.6	8.2	51.7	39.8	5.7	71.0	9.1	Operation Not Recommended						
	15.0	6.0	13.9	52.7	40.2	5.5	71.4	9.6							
160	7.5	1.6	3.7	46.4	37.8	6.9	69.8	6.8	Operation Not Recommended						
	11.3	3.4	7.8	48.4	38.5	6.4	70.1	7.6							
170	15.0	5.8	13.4	49.4	38.9	6.1	70.4	8.0	Operation Not Recommended						

Notes:

- Interpolation is permissible; extrapolation is not.
- All entering air conditions are 80°F (26.6°C) DB and 67°F (19.4°C) WB in cooling, and 70°F (21°C) DB in heating.
- Table does not reflect fan or pump power corrections for AHRI/ISO conditions.
- All performance is based upon the lower voltage of dual voltage rated units.
- Performance stated is at the rated power supply; performance may vary as the power supply varies from the rated.
- Operation below 40°F (4.4°C) is based upon 20% methanol antifreeze solution.
- Operation below 60°F (15.5°C) EWT requires optional insulated water/refrigerant circuit.
- See performance correction tables for operating conditions other than those listed above.
- See Performance Data Selection Notes for operation in the shaded areas.
- Performance capacities shown in thousands of Btu/h.
- For unit operation in the shaded area when LWT is below 40°F (4.4°C), antifreeze must be used and the JW3 jumper on the DXM2.5/CXM2 should be clipped. This is due to the potential of the refrigerant temperature being as low as 32°F (0°C) with 40°F (4.4°C) LWT, which may lead to a nuisance cutout due to the activation of the Low Temperature Protection. JW3 should never be clipped for standard range equipment or systems without antifreeze.

CV EC MOTOR ADVANTAGE

A major benefit of the CV EC motor over other blower motor types is its ability to adjust airflow remotely through the iGate 2 web portal/mobile app or directly at the unit with a communicating diagnostic service tool. Airflow levels can be adjusted in increments of 25 CFM from the unit's minimum and maximum CFM range (see the CV EC motor configuration table for details).

Table 1: CV EC Blower Motor Limits

Size	Max ESP (in. wg)	Fan Motor (hp)	Airflow Range	Cooling Mode	Heating Mode	Dehumid Mode	Fan Only
6	0.9	1/8	Minimum	150	150	150	150
	1.0		Default	275	275	150	275
	1.0		Maximum	275	275	225	275
9	0.9	1/8	Minimum	225	225	225	225
	0.9		Default	345	345	225	345
	0.9		Maximum	375	375	325	375
12	0.8	1/4	Minimum	300	300	300	300
	0.8		Default	400	400	300	400
	0.9		Maximum	415	415	380	415
15	0.8	1/3	Minimum	375	375	375	375
	1.0		Default	525	525	375	525
	1.0		Maximum	625	625	600	625
18	0.8	1/3	Minimum	450	450	450	450
	0.9		Default	630	630	450	630
	0.9		Maximum	750	750	600	750
24	0.75	1/2	Minimum	600	600	600	300
			Default	750	750	650	350
			Maximum	850	850	800	850
30	0.5	1/2	Minimum	750	750	750	375
			Default	925	925	800	425
			Maximum	1,050	1,050	1,000	1,050
36	0.6	3/4	Minimum	900	900	900	450
			Default	1,125	1,125	975	525
			Maximum	1,275	1,275	1,200	1,275
42	0.6	3/4	Minimum	1,050	1,050	1,050	525
			Default	1,300	1,300	1,125	600
			Maximum	1,475	1,475	1,400	1,475
48	0.6	3/4	Minimum	1,200	1,200	1,200	600
			Default	1,500	1,500	1,300	700
			Maximum	1,700	1,700	1,600	1,700
60	0.75	1	Minimum	1,500	1,500	1,500	750
			Default	1,875	1,875	1,625	875
			Maximum	2,125	2,125	2,000	2,125

- Airflow is controlled within ±5% up to Max ESP shown with wet coil and standard 1-inch fiberglass air filter.
- Performance shown is with wet coil and factory air filters.

Cooling Corrections

Full Load Cooling Corrections									
Ent Air WB F	Total Clg Cap	Sens Clg Cap Multipliers- Entering DB F						Power	Heat of Rejection
		65	70	75	80	85	90		
50	0.708	1.158	*	*	*	*	*	1.004	0.775
55	0.794	0.895	1.101	*	*	*	*	1.003	0.852
60	0.880	0.686	0.891	1.097	*	*	*	1.002	0.914
65	0.966		0.680	0.884	1.086	1.293	*	1.000	0.975
67	1.000		0.596	0.799	1.000	1.207	1.410	1.000	1.000
70	1.052			0.672	0.871	1.077	1.280	0.999	1.037
75	1.138				0.657	0.862	1.063	0.998	1.098

* Sensible Capacity equals Total Capacity.
AHRI/ISO/ASHRAE 13256-1 uses entering air conditions of Cooling - 80.6°F DB/ 66.2°F WB, and Heating - 68°F DB/ 59°F WB entering air temperature.
Entering DB temperature range is based on operating limits, not on commission limits.
Cooling air corrections based on rated airflow.

Heating Corrections

Full EAT Heating Corrections			
Ent Air DB °F	Heating Capacity	Power	Heat of Extraction
50	1.022	0.775	1.086
55	1.016	0.841	1.060
60	1.011	0.894	1.040
65	1.005	0.947	1.020
70	1.000	1.000	1.000
75	0.995	1.053	0.980
80	0.989	1.106	0.960

Heating air corrections based on rated airflow.

Airflow Correction Table

Full Airflow Corrections								
Airflow % of Rated	Heating			Cooling				
	Heating Capacity	Heating Power	Heat of Extraction	Total Capacity	Sensible Capacity	Sens/Total Ratio	Power	Heat of Rejection
80	0.979	1.044	0.969	0.970	0.904	0.932	0.968	0.974
85	0.984	1.033	0.977	0.977	0.928	0.950	0.976	0.980
90	0.989	1.022	0.985	0.985	0.952	0.967	0.984	0.987
95	0.995	1.011	0.992	0.992	0.976	0.983	0.992	0.993
100	1.000	1.000	1.000	1.000	1.000	1.000	1.000	1.000
105	1.005	0.989	1.008	1.008	1.024	1.016	1.008	1.007
110	1.011	0.978	1.015	1.015	1.048	1.032	1.016	1.013

Cooling and heating air corrections based on rated airflow.

Antifreeze Correction Table

Models:
SC
006-060

EWT (°F)	Antifreeze Type	Antifreeze %	Cooling			Heating		WPD
			Total Cap	Sensible Cap	Watts	Total Cap	Watts	
90	Water	0%	1.000	1.000	1.000	1.000	1.000	1.000
	Ethanol	5%	0.998	0.998	1.002	0.996	0.999	1.025
		10%	0.996	0.996	1.003	0.991	0.997	1.048
		15%	0.994	0.994	1.005	0.987	0.996	1.098
		20%	0.991	0.991	1.006	0.982	0.994	1.142
		25%	0.986	0.986	1.009	0.972	0.991	1.207
		30%	0.981	0.981	1.012	0.962	0.988	1.265
		35%	0.977	0.977	1.015	0.953	0.985	1.312
		40%	0.972	0.972	1.018	0.943	0.982	1.370
		45%	0.966	0.966	1.023	0.931	0.978	1.431
		50%	0.959	0.959	1.027	0.918	0.974	1.494
	Ethylene Glycol	5%	0.998	0.998	1.002	0.996	0.999	1.021
		10%	0.996	0.996	1.003	0.991	0.997	1.040
		15%	0.994	0.994	1.004	0.987	0.996	1.079
		20%	0.991	0.991	1.005	0.982	0.995	1.114
		25%	0.988	0.988	1.008	0.976	0.993	1.146
		30%	0.985	0.985	1.010	0.969	0.990	1.175
		35%	0.982	0.982	1.012	0.963	0.988	1.208
		40%	0.979	0.979	1.014	0.956	0.986	1.243
		45%	0.976	0.976	1.016	0.950	0.984	1.278
		50%	0.972	0.972	1.018	0.943	0.982	1.314
	Methanol	5%	0.997	0.997	1.002	0.993	0.998	1.039
		10%	0.993	0.993	1.004	0.986	0.996	1.075
		15%	0.990	0.990	1.007	0.979	0.994	1.116
		20%	0.986	0.986	1.009	0.972	0.991	1.154
		25%	0.982	0.982	1.012	0.964	0.989	1.189
		30%	0.978	0.978	1.014	0.955	0.986	1.221
		35%	0.974	0.974	1.017	0.947	0.984	1.267
		40%	0.970	0.970	1.020	0.939	0.981	1.310
		45%	0.966	0.966	1.023	0.930	0.978	1.353
		50%	0.961	0.961	1.026	0.920	0.975	1.398
	Propylene Glycol	5%	0.995	0.995	1.003	0.990	0.997	1.065
		10%	0.990	0.990	1.006	0.980	0.994	1.119
		15%	0.986	0.986	1.009	0.971	0.991	1.152
		20%	0.981	0.981	1.012	0.962	0.988	1.182
		25%	0.978	0.978	1.014	0.956	0.986	1.227
		30%	0.975	0.975	1.016	0.950	0.984	1.267
		35%	0.972	0.972	1.018	0.944	0.982	1.312
		40%	0.969	0.969	1.020	0.938	0.980	1.356
		45%	0.965	0.965	1.023	0.929	0.977	1.402
		50%	0.960	0.960	1.026	0.919	0.974	1.450

Table continued on next page

ClimateMaster works continually to improve its products. As a result, the design and specifications of each product at the time of order may be changed without notice and may not be as described herein. Please contact ClimateMaster's Customer Service Department at 800-299-9747 for specific information on the current design and specifications. Statements and other information contained herein are not express warranties and do not form the basis of any bargain between the parties, but are merely ClimateMaster's opinion or commendation of its products. The latest version of this document is available at www.climatemaster.com. Engineered and assembled in the USA. © ClimateMaster, Inc. All Rights Reserved 2024

Antifreeze Correction Table

Models:
SC
006-060

Table continued from previous page

EWT (°F)	Antifreeze Type	Antifreeze %	Cooling			Heating		WPD
			Total Cap	Sensible Cap	Watts	Total Cap	Watts	
30	Water	0%	1.000	1.000	1.000	1.000	1.000	1.000
	Ethanol	5%	0.991	0.991	1.006	0.981	0.994	1.140
		10%	0.981	0.981	1.012	0.961	0.988	1.242
		15%	0.973	0.973	1.018	0.944	0.983	1.295
		20%	0.964	0.964	1.024	0.927	0.977	1.343
		25%	0.959	0.959	1.028	0.917	0.974	1.363
		30%	0.954	0.954	1.031	0.907	0.970	1.383
		35%	0.949	0.949	1.035	0.897	0.967	1.468
		40%	0.944	0.944	1.038	0.887	0.964	1.523
		45%	0.940	0.940	1.041	0.880	0.962	1.580
		50%	0.936	0.936	1.043	0.872	0.959	1.639
	Ethylene Glycol	5%	0.997	0.997	1.002	0.993	0.998	1.040
		10%	0.993	0.993	1.004	0.986	0.996	1.075
		15%	0.990	0.990	1.006	0.980	0.994	1.122
		20%	0.987	0.987	1.008	0.973	0.992	1.163
		25%	0.983	0.983	1.011	0.966	0.990	1.195
		30%	0.979	0.979	1.013	0.958	0.987	1.225
		35%	0.976	0.976	1.016	0.951	0.985	1.279
		40%	0.972	0.972	1.018	0.943	0.982	1.324
		45%	0.969	0.969	1.021	0.937	0.980	1.371
		50%	0.966	0.966	1.023	0.930	0.978	1.419
	Methanol	5%	0.995	0.995	1.004	0.989	0.997	1.069
		10%	0.989	0.989	1.007	0.978	0.993	1.127
		15%	0.984	0.984	1.011	0.968	0.990	1.164
		20%	0.979	0.979	1.014	0.957	0.986	1.197
		25%	0.975	0.975	1.017	0.949	0.984	1.216
		30%	0.971	0.971	1.019	0.941	0.981	1.235
		35%	0.967	0.967	1.022	0.933	0.979	1.286
		40%	0.963	0.963	1.025	0.924	0.976	1.323
		45%	0.959	0.959	1.028	0.917	0.974	1.360
		50%	0.955	0.955	1.030	0.910	0.971	1.399
	Propylene Glycol	5%	0.995	0.995	1.004	0.989	0.997	1.071
		10%	0.989	0.989	1.007	0.978	0.993	1.130
		15%	0.985	0.985	1.010	0.968	0.990	1.206
		20%	0.980	0.980	1.013	0.958	0.987	1.270
		25%	0.974	0.974	1.017	0.947	0.983	1.359
		30%	0.968	0.968	1.021	0.935	0.979	1.433
		35%	0.963	0.963	1.025	0.924	0.976	1.522
		40%	0.957	0.957	1.029	0.913	0.972	1.614
		45%	0.949	0.949	1.034	0.898	0.967	1.712
		50%	0.941	0.941	1.039	0.882	0.962	1.816

ClimateMaster works continually to improve its products. As a result, the design and specifications of each product at the time of order may be changed without notice and may not be as described herein. Please contact ClimateMaster's Customer Service Department at 800-299-9747 for specific information on the current design and specifications. Statements and other information contained herein are not express warranties and do not form the basis of any bargain between the parties, but are merely ClimateMaster's opinion or commendation of its products. The latest version of this document is available at www.climatemaster.com. Engineered and assembled in the USA. © ClimateMaster, Inc. All Rights Reserved 2024

Blower Performance SC*006

Models:
SC
006-060

Model	Rated CFM	Min CFM	Motor Type	Speed Tap	External Static Pressure (in. wg)																
					0.1	0.2	0.3	0.4	0.5	0.6	0.7	0.8	0.9	1.0							
SC006	275	150	PSC	Low	Power (W)	72	69	65	61	57	Operation Not Recommended										
					CFM	238	218	196	170	142											
				Medium	Power (W)	81	77	73	68	63						58					
					CFM	261	242	220	193	163						129					
				High	Power (W)	103	98	93	88	82						75	68				
					CFM	326	306	282	253	219						181	139				
	275	150	CTEC	1	Power (W)	22	24	25	28	30											
					CFM	225	207	187	169	150											
				2	Power (W)	Operation Not Recommended			34	37						39	42	44	48	51	
					CFM	Operation Not Recommended			233	217						201	185	173	164	150	
				3	Power (W)	Operation Not Recommended			43	45						48	51	54	58	61	
					CFM	Operation Not Recommended			241	227						212	200	188	179	168	
				4	Power (W)	Operation Not Recommended			Operation Not Recommended							55	58	61	65	67	
					CFM	Operation Not Recommended			Operation Not Recommended							240	227	216	205	193	
	275	150	CV EC	Minimum CFM	Power (W)	16	21	27	40	36						41	46	52	59		
					CFM	150	150	150	150	150						150	150	150	150		
				Default CFM	Power (W)	29	35	41	47	53						60	67	76	81	77	
					CFM	225	225	225	225	225						225	225	225	225	225	
Maximum CFM				Power (W)	35	41	47	53	60	67	76	84	88	78							
				CFM	250	250	250	250	250	250	250	250	250	250							

- Blower performance data is based on the lowest nameplate voltage setting.
- Blower performance is based on a wet coil with clean 1-inch filter.
- Blower performance is based on operating conditions of 80°F DB and 67°F WB.
- CFM Tolerance is ±7%.
- Cells in grey - option not available.
- The maximum allowable altitude of installation for this product is 6,561 ft (2,000 m).

Blower Performance SC*009

Models:
SC
006-060

Model	Rated CFM	Min CFM	Motor Type	Speed Tap	External Static Pressure (in. wg)																																																						
					0.1	0.2	0.3	0.4	0.5	0.6	0.7	0.8	0.9	1.0																																													
SC009	345	225	PSC	Low	Power (W)	Operation Not Recommended																																																					
					CFM											340	322	300	260																																								
				Medium	Power (W)											Operation Not Recommended																																											
					CFM																					390	360	320	290	260																													
				High	Power (W)																					Operation Not Recommended																																	
					CFM																															410	380	350	320	280																			
	345	225	CTEC	1	Power (W)																															40	42	44	47	49	Operation Not Recommended																		
					CFM																															294	278	259	245	230																			
				2	Power (W)																															67	70	73	74	79						82	85	88	90	85									
					CFM																															370	357	343	326	318						302	291	278	265	235									
				3	Power (W)																															Operation Not Recommended			86	88						91	95	98	101	96	90								
					CFM																																		370	358						346	334	322	307	280	247								
				4	Power (W)																																		Operation Not Recommended							120	113	107	102										
					CFM																																									340	309	276	234										
	345	225	CV EC	Minimum CFM	Power (W)																																									25	32	39	45	53	60	66	78	83					
					CFM																																									225	225	225	225	225	225	225	225	225					
				Default CFM	Power (W)																																									49	58	67	77	88	100	105	95	88					
					CFM																																									325	325	325	325	325	325	325	325	325					
Maximum CFM				Power (W)	126	134	131	125	119	118	105	98	90																																														
				CFM	375	375	375	375	375	375	375	375	375																																														

- Blower performance data is based on the lowest nameplate voltage setting.
- Blower performance is based on a wet coil with clean 1-inch filter.
- Blower performance is based on operating conditions of 80°F DB and 67°F WB.
- CFM Tolerance is ±7%.
- Cells in grey - option not available.
- The maximum allowable altitude of installation for this product is 6,561 ft (2,000 m).

Blower Performance SC*012

Models:
SC
006-060

Model	Rated CFM	Min CFM	Motor Type	Speed Tap	External Static Pressure (in. wg)										
					0.1	0.2	0.3	0.4	0.5	0.6	0.7	0.8	0.9	1.0	
SC012	400	300	PSC	Low	Power (W)	Operation Not Recommended									
					CFM	360	350	320	310						
				Medium	Power (W)	Operation Not Recommended									
					CFM	420	400	380	360	340					
				High	Power (W)	Operation Not Recommended									
					CFM	470	450	430	400	380	320				
	400	300	CTEC	1	Power (W)	64	66	69	71	75	78	82	85	87	83
					CFM	358	345	332	319	305	291	275	261	247	218
				2	Power (W)	86	88	91	94	97	100	103	104	97	91
					CFM	400	388	377	365	354	342	328	309	269	237
				3	Power (W)	116	119	122	124	126	126	121	114	99	91
					CFM	449	437	427	414	401	385	359	327	274	238
				4	Power (W)	131	133	135	137	135	130	123	110	99	92
					CFM	467	456	444	433	414	390	361	318	273	239
	400	300	CV EC	Minimum CFM	Power (W)	55	64	73	81	90	99	107	106		
					CFM	300	300	300	300	300	300	300	300		
				Default CFM	Power (W)	105	115	125	135	132	127	123	118		
					CFM	380	380	380	380	380	380	380	380		
Maximum CFM				Power (W)	147	149	146	143	139	134	130	126	120		
				CFM	415	415	415	415	415	415	415	415	415		

- Blower performance data is based on the lowest nameplate voltage setting.
- Blower performance is based on a wet coil with clean 1-inch filter.
- Blower performance is based on operating conditions of 80°F DB and 67°F WB.
- CFM Tolerance is ±7%.
- Cells in grey - option not available.
- The maximum allowable altitude of installation for this product is 6,561 ft (2,000 m).

Blower Performance SC*015

Models:
SC
006-060

Model	Rated CFM	Min CFM	Motor Type	Speed Tap		External Static Pressure (in. wg)															
						0.1	0.2	0.3	0.4	0.5	0.6	0.7	0.8	0.9	1.0						
SC015	525	375	PSC	Low	Power (W)	161	158	146	138	Operation Not Recommended											
					CFM	503	490	479	439												
				Medium	Power (W)	184	181	174	153											143	
					CFM	595	575	562	510											451	
				High	Power (W)				174											159	141
					CFM				581											510	386
	525	375	CTEC	1	Power (W)	67	55	62	68	75	82										
					CFM	648	588	542	493	441	378										
				2	Power (W)	67	74	81	87	95	102	108									
					CFM	648	608	557	514	460	402	354									
				3	Power (W)	79	86	94	101	107	117	124	130								
					CFM	695	659	611	570	526	475	422	377								
				4	Power (W)	92	98	107	114	121	129	138	145	151							
					CFM	737	705	661	622	582	534	482	438	396							
				5	Power (W)	106	110	117	126	133	141	151	159	165	172						
					CFM	745	745	708	662	626	585	535	488	444	402						
	525	375	CV EC	Minimum CFM	Power (W)				36	52	68	84	99	114	129						
					CFM				375	375	375	375	375	375	375	375					
				Default CFM	Power (W)				55	74	90	108	127	147	166	186					
					CFM				525	525	525	525	525	525	525	525	525				
Maximum CFM				Power (W)	54	73	93	112	132	152	173	194	216	238							
				CFM	625	625	625	625	625	625	625	625	625	625	625	625					

- Blower performance data is based on the lowest nameplate voltage setting.
- Blower performance is based on a wet coil with clean 1-inch filter.
- Blower performance is based on operating conditions of 80°F DB and 67°F WB.
- CFM Tolerance is ±7%.
- Cells in grey - option not available.
- The maximum allowable altitude of installation for this product is 6,561 ft (2,000 m).

Blower Performance SC*018

Models:
SC
006-060

Model	Rated CFM	Min CFM	Motor Type	Speed Tap		External Static Pressure (in. wg)															
						0.1	0.2	0.3	0.4	0.5	0.6	0.7	0.8	0.9	1.0						
SC018	630	450	PSC	Low	Power (W)	147	145	135	127	Operation Not Recommended											
					CFM	524	509	493	451												
				Medium	Power (W)	170	167	161	143												
					CFM	611	588	564	514												
				High	Power (W)	195	189	184	177							149					
					CFM	704	668	643	617							504					
	630	450	CTEC	1	Power (W)	73	78	85	90	Operation Not Recommended											
					CFM	600	558	518	491												
				2	Power (W)	92	99	107	109							116	123	131			
					CFM	676	641	599	570							536	498	452			
				3	Power (W)	112	118	126	135							140	147	155	163	170	
					CFM	741	713	677	640							619	586	554	512	471	
				4	Power (W)	138	144	152	161							170	174	181	190	199	207
					CFM	802	780	751	714							680	662	633	603	567	529
				5	Power (W)	170	175	182	190							201	210	214	222	231	240
					CFM	854	848	820	791							754	724	711	683	655	625
	630	450	CV EC	Minimum CFM	Power (W)	Operation Not Recommended				93	111	132	157	180	Operation Not Recommended						
					CFM	Operation Not Recommended				450	450	450	450	450							
				Default CFM	Power (W)	85	101	113	145	178	206	228	248	266							
					CFM	600	600	600	600	600	600	600	600	600							
Maximum CFM				Power (W)	157	171	186	200	214	251	286	323	Operation Not Recommended								
				CFM	750	750	750	750	750	750	750	750									

- Blower performance data is based on the lowest nameplate voltage setting.
- Blower performance is based on a wet coil with clean 1-inch filter.
- Blower performance is based on operating conditions of 80°F DB and 67°F WB.
- CFM Tolerance is ±7%.
- Cells in grey - option not available.
- The maximum allowable altitude of installation for this product is 6,561 ft (2,000 m).

Blower Performance SC*024

Models:
SC
006-060

Model	Rated CFM	Min CFM	Motor Type	Speed Tap		External Static Pressure (in. wg)																					
						0.1	0.2	0.3	0.4	0.5	0.6	0.7	0.8	0.9	1.0												
SC024	800	600	PSC	Low	Power (W)	224	215	204	191	176	Operation Not Recommended																
					CFM	777	768	737	684	608																	
				Medium	Power (W)	257	246	233	219	204							187										
					CFM	888	868	830	774	701							610										
				High	Power (W)	294	281	268	253	237							219										
					CFM	997	964	916	854	777							686										
	800	600	CTEC	1	Power (W)	116	122	128	135	Operation Not Recommended																	
					CFM	755	728	695	653																		
				2	Power (W)	146	152	159	166								174	185	193								
					CFM	836	810	782	750								708	657	616								
				3	Power (W)	181	187	194	201								209	218	230	239	246	252					
					CFM	910	887	861	834								804	762	714	674	642	619					
				4	Power (W)	232	240	247	254							262	270	278	291	303	312						
					CFM	996	975	952	929							904	876	845	798	755	725						
				5	Power (W)	Operation Not Recommended										323	331	340	348	361	374						
					CFM											999	975	951	923	884	840						
	800	600	CV EC	Minimum CFM	Power (W)	71	89	107	124							141	159	177	195	213	230						
					CFM	600	600	600	600							600	600	600	600	600	600						
				Default CFM	Power (W)	145	165	185	205	225	245	266	285	306	326												
					CFM	800	800	800	800	800	800	800	800	800	800												
Maximum CFM				Power (W)	284	300	315	332	351	364	379	396	412	428													
				CFM	1,000	1,000	1,000	1,000	1,000	1,000	1,000	1,000	1,000	1,000													

- Blower performance data is based on the lowest nameplate voltage setting.
- Blower performance is based on a wet coil with clean 1-inch filter.
- Blower performance is based on operating conditions of 80°F DB and 67°F WB.
- CFM Tolerance is ±7%.
- Cells in grey - option not available.
- The maximum allowable altitude of installation for this product is 6,561 ft (2,000 m).

Blower Performance SC*030

Models:
SC
006-060

Model	Rated CFM	Min CFM	Motor Type	Speed Tap		External Static Pressure (in. wg)																	
						0.1	0.2	0.3	0.4	0.5	0.6	0.7	0.8	0.9	1.0								
SC030	1,000	750	PSC	Low	Power (W)	305	290	274	256	236	Operation Not Recommended												
					CFM	916	911	883	833	761													
				Medium	Power (W)	338	323	306	288	268						246							
					CFM	1,021	1,014	983	929	850						747							
				High	Power (W)	384	372	357	340	322						301							
					CFM	1,084	1,076	1,044	988	906						800							
	1,000	750	CTEC	1	Power (W)	158	165	176	184	192	Operation Not Recommended												
					CFM	904	873	832	796	763													
				2	Power (W)	211	219	227	240	250						258	267	276	285				
					CFM	1,020	992	965	927	894						864	835	805	771				
				3	Power (W)	280	289	298	306	321						330	342	351	361	368			
					CFM	1,139	1,113	1,089	1,064	1,027						999	966	937	910	879			
				4	Power (W)	336	346	355	364	374						389	399	413	423	430			
					CFM	1,216	1,193	1,168	1,146	1,123						1,086	1,062	1,028	1,002	975			
				5	Power (W)				452	462						471	490	499	508	478			
					CFM				1,250	1,229						1,208	1,173	1,151	1,112	1,036			
				1,000	750	CV EC	Minimum CFM	Power (W)	71	89						108	127	145	162	181	199	217	235
								CFM	750	750						750	750	750	750	750	750	750	750
	Default CFM	Power (W)	251				274	296	315	337	362	387	407	Operation Not Recommended									
		CFM	1,000				1,000	1,000	1,000	1,000	1,000	1,000	1,000										
Maximum CFM	Power (W)	388	410				431	453	471	Operation Not Recommended													
	CFM	1,150	1,150				1,150	1,150	1,150														

- Blower performance data is based on the lowest nameplate voltage setting.
- Blower performance is based on a wet coil with clean 1-inch filter.
- Blower performance is based on operating conditions of 80°F DB and 67°F WB.
- CFM Tolerance is ±7%.
- Cells in grey - option not available.
- The maximum allowable altitude of installation for this product is 6,561 ft (2,000 m).

Blower Performance

SC*036

Models:
SC
006-060

Model	Rated CFM	Min CFM	Motor Type	Speed Tap	External Static Pressure (in. wg)																																													
					0.1	0.2	0.3	0.4	0.5	0.6	0.7	0.8	0.9	1.0																																				
SC036	1,150	900	PSC	Low	Power (W)	Operation Not Recommended																																												
					CFM											970	960	951	941	902																														
				Medium	Power (W)											Operation Not Recommended																																		
					CFM																					1,106	1,096	1,086	1,067	1,009	912																			
				High	Power (W)																					Operation Not Recommended																								
					CFM																															1,436	1,387	1,329	1,280	1,174	1,077	931								
	1,150	900	CTEC	1	Power (W)																															166	175	184	Operation Not Recommended											
					CFM																															974	941	904												
				2	Power (W)																															241	251	261								272	282	292	299	307
					CFM																															1,132	1,103	1,074								1,041	1,005	973	944	916
				3	Power (W)	294	304	316	326	337	349	359	367	375	385																																			
					CFM	1,271	1,242	1,214	1,185	1,153	1,118	1,083	1,056	1,029	999																																			
				4	Power (W)	376	387	399	409	421	433	446	457	468	478																																			
					CFM	1,403	1,377	1,351	1,324	1,295	1,268	1,233	1,201	1,169	1,143																																			
				5	Power (W)	Operation Not Recommended		499	510	523	524	521	519	516	514																																			
					CFM			1,485	1,460	1,434	1,396	1,347	1,295	1,240	1,194																																			
	1,150	900	CV EC	Minimum CFM	Power (W)	105	132	164	188	211	233	257	280	307	339																																			
					CFM	900	900	900	900	900	900	900	900	900	900																																			
				Default CFM	Power (W)	205	232	261	303	349	382	415	446	475	505																																			
					CFM	1,150	1,150	1,150	1,150	1,150	1,150	1,150	1,150	1,150	1,150																																			
Maximum CFM				Power (W)	406	403	438	474	511	564	629	680	692	691																																				
				CFM	1,500	1,500	1,500	1,500	1,500	1,500	1,500	1,500	1,500	1,500																																				

- Blower performance data is based on the lowest nameplate voltage setting.
- Blower performance is based on a wet coil with clean 1-inch filter.
- Blower performance is based on operating conditions of 80°F DB and 67°F WB.
- CFM Tolerance is ±7%.
- Cells in grey - option not available.
- The maximum allowable altitude of installation for this product is 6,561 ft (2,000 m).

Blower Performance SC041

Models:
SC
006-060

Model	Rated CFM	Min CFM	Motor Type	Speed Tap	External Static Pressure (in. wg)												
					0.1	0.2	0.3	0.4	0.5	0.6	0.7	0.8	0.9	1.0			
SC041	1,100	850	PSC	Low	Power (W)	291	268	Operation Not Recommended									
					CFM	876	810										
				Medium	Power (W)	359	355									337	
					CFM	1017	963									887	
				High	Power (W)	392	369									347	325
					CFM	1071	993									906	809

- Blower performance data is based on the lowest nameplate voltage setting.
- Blower performance is based on a wet coil with clean 1-inch filter.
- Blower performance is based on operating conditions of 80°F DB and 67°F WB.
- CFM Tolerance is ±7%.
- Cells in grey - option not available.
- The maximum allowable altitude of installation for this product is 6,561 ft (2,000 m).

Blower Performance SC*042

Models:
SC
006-060

Model	Rated CFM	Min CFM	Motor Type	Speed Tap		External Static Pressure (in. wg)										
						0.1	0.2	0.3	0.4	0.5	0.6	0.7	0.8	0.9	1.0	
SC042	1,350	1,050	PSC	Low	Power (W)	388	Operation Not Recommended									
					CFM	918	Operation Not Recommended									
				Medium	Power (W)	517	509	496	477	452	422	Operation Not Recommended				
					CFM	1,201	1,223	1,218	1,185	1,125	1,038	Operation Not Recommended				
				High	Power (W)	665	654	636	611	580	542	498	Operation Not Recommended			
					CFM	1,584	1,592	1,571	1,518	1,436	1,323	1,180	Operation Not Recommended			
	1,350	1,050	CTEC	1	Power (W)	238	248	259	272	Operation Not Recommended						
					CFM	1,186	1,152	1,113	1,056	Operation Not Recommended						
				2	Power (W)	331	369	352	365	381	396	411	423	437	446	
					CFM	1,345	1,317	1,283	1,251	1,215	1,181	1,150	1,124	1,094	1,050	
				3	Power (W)	448	461	474	486	501	518	534	551	568	581	
					CFM	1,507	1,482	1,455	1,427	1,396	1,365	1,331	1,296	1,276	1,246	
				4	Power (W)	582	595	609	622	635	651	669	688	706	681	
					CFM	1,641	1,623	1,601	1,577	1,548	1,519	1,488	1,455	1,423	1,355	
				5	Power (W)	Operation Not Recommended		756	775	776	774	772	768	765	679	
					CFM	Operation Not Recommended		1,743	1,717	1,688	1,645	1,596	1,541	1,490	1,352	
	1,350	1,050	CV EC	Minimum CFM	Power (W)	154	177	200	224	252	280	306	331	355	383	
					CFM	1,050	1,050	1,050	1,050	1,050	1,050	1,050	1,050	1,050	1,050	
				Default CFM	Power (W)	334	359	390	421	453	484	517	555	595	636	
					CFM	1,400	1,400	1,400	1,400	1,400	1,400	1,400	1,400	1,400	1,400	
Maximum CFM				Power (W)	658	674	703	700	697	Operation Not Recommended						
				CFM	1,750	1,750	1,750	1,750	1,750	Operation Not Recommended						

- Blower performance data is based on the lowest nameplate voltage setting.
- Blower performance is based on a wet coil with clean 1-inch filter.
- Blower performance is based on operating conditions of 80°F DB and 67°F WB.
- CFM Tolerance is ±7%.
- Cells in grey - option not available.
- The maximum allowable altitude of installation for this product is 6,561 ft (2,000 m).

Blower Performance SC*048

Models:
SC
006-060

Model	Rated CFM	Min CFM	Motor Type	Speed Tap		External Static Pressure (in. wg)														
						0.1	0.2	0.3	0.4	0.5	0.6	0.7	0.8	0.9	1.0					
SC048	1,550	1,200	PSC	Low	Power (W)	608	585	559	531	499	Operation Not Recommended									
					CFM	1,512	1,487	1,440	1,371	1,280										
				Medium	Power (W)	680	652	622	588	552						513				
					CFM	1,670	1,639	1,584	1,507	1,406						1,281				
				High	Power (W)	780	746	709	669	625						579	529			
					CFM	1,885	1,841	1,772	1,678	1,560						1,416	1,248			
	1,550	1,200	CTEC	1	Power (W)	286	303	320	336	351										
					CFM	1,482	1,411	1,342	1,276	1,211										
				2	Power (W)	360	379	397	415	433						450	467			
					CFM	1,604	1,553	1,500	1,444	1,385						1,323	1,258			
				3	Power (W)	457	472	488	505	525						546	569			
					CFM	1,753	1,707	1,659	1,607	1,553						1,495	1,435			
				4	Power (W)	626	642	658	673	687						701				
					CFM	1,984	1,937	1,890	1,843	1,795						1,747				
				5	Power (W)				805	829										
					CFM				1,980	1,938										
	1,550	1,200	CV EC	Minimum CFM	Power (W)	240	132	163	293	342						309	280	395	401	453
					CFM	1,200	1,200	1,200	1,200	1,200						1,200	1,200	1,200	1,200	1,200
Default CFM				Power (W)	445	251	294	500	570	498	438	617	602	672						
				CFM	1,550	1,550	1,550	1,550	1,550	1,550	1,550	1,550	1,550	1,550						
Maximum CFM				Power (W)	723	418	474	780	873	761	644	912	853	939						
				CFM	1,900	1,900	1,900	1,900	1,900	1,900	1,900	1,900	1,900	1,900						

- Blower performance data is based on the lowest nameplate voltage setting.
- Blower performance is based on a wet coil with clean 1-inch filter.
- Blower performance is based on operating conditions of 80°F DB and 67°F WB.
- CFM Tolerance is ±7%.
- Cells in grey - option not available.
- The maximum allowable altitude of installation for this product is 6,561 ft (2,000 m).

Blower Performance SC*060

Models:
SC
006-060

Model	Rated CFM	Min CFM	Motor Type	Speed Tap		External Static Pressure (in. wg)																						
						0.1	0.2	0.3	0.4	0.5	0.6	0.7	0.8	0.9	1.0													
SC060	2,000	1,500	PSC	Low	Power (W)	779	766	750	731	710	686	659	Operation Not Recommended															
					CFM	1,771	1,756	1,732	1,700	1,658	1,608	1,549																
				Medium	Power (W)	877	856	833	806	777	744	708					669											
					CFM	1,979	1,968	1,940	1,894	1,831	1,751	1,653					1,539											
				High	Power (W)	996	969	938	904	867	826	783					736	687										
					CFM	2,208	2,178	2,132	2,069	1,990	1,893	1,780					1,649	1,502										
	2,000	1,500	CTEC	1	Power (W)	342	354	366	380	Operation Not Recommended																		
					CFM	1,685	1,640	1,593	1,545																			
				2	Power (W)	460	476	489	501								518	533	548	561	577							
					CFM	1,879	1,833	1,795	1,754								1,705	1,657	1,608	1,563	1,514							
				3	Power (W)	648	666	678	694								708	724	740	757	773							
					CFM	2,113	2,069	2,039	1,998								1,963	1,925	1,885	1,840	1,795							
				4	Power (W)	771	785	803	817								832	848	864	883	900							
					CFM	2,235	2,198	2,163	2,130								2,094	2,061	2,019	1,977	1,939							
				5	Power (W)	866	881	899	916								934	951	970	977	973	969						
					CFM	2,322	2,290	2,253	2,219								2,188	2,152	2,120	2,083	2,013	1,940						
				2,000	1,500	CV EC	Minimum CFM	Power (W)	246								301	354	405	453	500	544	587	627	665			
								CFM	1,500								1,500	1,500	1,500	1,500	1,500	1,500	1,500	1,500	1,500			
Default CFM	Power (W)	503	564				631	686	734							808	875	929	990	1,051								
	CFM	2,000	2,000				2,000	2,000	2,000							2,000	2,000	2,000	2,000	2,000								
Maximum CFM	Power (W)	885	896				901	916	937							Operation Not Recommended												
	CFM	2,200	2,200				2,200	2,200	2,200																			

- Blower performance data is based on the lowest nameplate voltage setting.
- Blower performance is based on a wet coil with clean 1-inch filter.
- Blower performance is based on operating conditions of 80°F DB and 67°F WB.
- CFM Tolerance is ±7%.
- Cells in grey - option not available.
- The maximum allowable altitude of installation for this product is 6,561 ft (2,000 m).

Tranquility (SC) Series

Unit Size	006	009	012	015	018	024	030	036	041	042	048	060
Number of refrigerant circuits	1	1	1	1	1	1	1	1	1	1	1	1
Factory Charge R-454B (oz)	17	18	21	29	37	40	39	46	53	56	56	69
Refrigerant Leak Detection System	O	O	O	O	O	O	O	O	O	O	O	R
Number of Sensors	2	2	2	2	2	2	2	2	2	2	2	2
Water Connection Size												
FPT	1/2"	1/2"	1/2"	1/2"	1/2"	3/4"	3/4"	3/4"	3/4"	3/4"	1"	1"
Coax Volume (gallons)	0.143	0.143	0.167	0.286	0.45	0.323	0.323	0.738	0.89	0.89	0.89	0.939
Vertical												
Filter Standard - 1" Throwaway	10x18	10x18	10x18	20x20	20x20	20x20	20x20	24x24	20x20	24x24	28x28	28x28
Weight - Operating (lbs.)	103	105	114	153	158	189	197	203	210	218	315	330
Weight - Packaged (lbs.)	113	115	124	158	163	194	202	209	217	224	322	337
Horizontal												
Filter Standard - 1" Throwaway	10x18	10x18	10x18	16x25	16x25	18x24	18x24	2-14x20		2-14x20	1-20x24 1-14x20	1-20x24 1-14x20
Weight - Operating (lbs.)	103	105	114	153	158	174	182	203		218	263	278
Weight - Packaged (lbs.)	113	115	124	158	163	179	187	209		224	270	285

Notes:

All dimensions displayed above are in inches unless otherwise marked.
 All units have a TXV and 1/2-inch and 3/4-inch electrical knockouts.
 The standard Condensate Drain Connection is a rubber coupling that couples to 3/4-inch schedule 40/80 PVC.
 The optional Stainless Steel Condensate Drain Connection is 3/4-inch FPT.
 FPT = Female Pipe Thread
 575V fan motors are two speed.
 O = Optional, R = Required

Unit Maximum Water Working Pressure

Options	Max Pressure PSIG [kPa]
Base Unit	300 [2,068]

Dimensional Data

Models:
SC
006-060

Cabinet, Shipping, Water Connections, and Condensate Drain Pan Dimensions (in)

Model	Cabinet Config.	Overall Cabinet			Shipping Overall Dimensions			Water Connections					Condensate Drain Pan		
		Depth/Length	Width	Height	Depth/Length	Width	Height	Water In		Water Out		Water In/Out	AA	BB	Condensate Drain Pan Fitting
		A	B	C	A	B	C	D	E	F	E				
SC006	H	34.1	19.1	11.0	40.0	25.1	17.0	5.7	1.0	9.7	1.0	1/2"	3.3	0.7	*3/4" MPT
	V	19.0	19.1	22.0	24.8	24.8	28.0	1.7	1.7	9.7	1.7	1/2"	11.7	1.5	*3/4" MPT
SC009	H	34.1	19.1	11.0	40.0	25.1	17.0	5.7	1.0	9.7	1.0	1/2"	3.3	0.7	*3/4" MPT
	V	19.0	19.1	22.0	24.8	24.8	28.0	1.7	1.7	9.7	1.7	1/2"	11.7	1.5	*3/4" MPT
	F	19.0	19.1	22.0	24.8	24.8	28.0	1.7	1.8	9.7	1.8	1/2"	11.7	1.5	*3/4" MPT
SC012	H	34.1	19.1	11.0	40.0	25.1	17.0	5.7	1.0	9.7	1.0	1/2"	3.3	0.7	*3/4" MPT
	V	19.0	19.1	22.0	24.8	24.8	28.0	1.7	1.7	9.7	1.7	1/2"	11.7	1.5	*3/4" MPT
	F	19.0	19.1	22.0	24.8	24.8	28.0	1.7	1.8	9.7	1.8	1/2"	11.7	1.5	*3/4" MPT
SC015	H	43.0	20.1	17.0	48.5	33.5	23.0	3.5	1.5	13.8	1.5	1/2"	3.4	1.0	*3/4" MPT
	V	21.5	21.6	40.0	27.3	27.3	46.0	3.7	1.5	9.7	1.5	1/2"	19.7	1.5	*3/4" MPT
	F	21.5	21.6	40.0	27.3	27.3	46.0	3.7	1.9	9.7	1.9	1/2"	19.7	1.5	*3/4" MPT
SC018	H	43.0	20.1	17.0	48.5	33.5	23.0	3.5	1.5	13.8	1.5	1/2"	3.4	1.0	*3/4" MPT
	V	21.5	21.6	40.0	27.3	27.3	46.0	3.7	1.5	9.7	1.5	1/2"	19.7	1.5	*3/4" MPT
	F	21.5	21.6	40.0	27.3	27.3	46.0	3.7	1.9	9.7	1.9	1/2"	19.7	1.5	*3/4" MPT
SC024	H	43.0	20.1	18.3	48.5	33.5	24.3	2.0	1.5	15.4	1.5	3/4"	3.5	0.8	*3/4" MPT
	V	21.5	21.6	40.0	27.3	27.3	46.0	3.7	1.5	9.8	1.5	3/4"	19.7	1.5	*3/4" MPT
	F	21.5	21.6	40.0	27.3	27.3	46.0	3.8	1.9	9.8	1.9	3/4"	19.7	1.5	*3/4" MPT
SC030	H	43.0	20.1	18.3	48.5	33.5	24.3	2.0	1.5	15.4	1.5	3/4"	3.5	0.8	*3/4" MPT
	V	21.5	21.6	40.0	27.3	27.3	46.0	3.7	1.5	9.8	1.5	3/4"	19.7	1.5	*3/4" MPT
	F	21.5	21.6	40.0	27.3	27.3	46.0	3.8	1.9	9.8	1.9	3/4"	19.7	1.5	*3/4" MPT
SC036	H	47.1	20.1	21.0	52.0	34.0	27.0	2.0	1.6	16.8	1.6	3/4"	3.4	0.8	*3/4" MPT
	V	26.0	21.6	45.0	31.8	27.3	51.0	3.7	1.5	9.8	1.5	3/4"	20.7	1.4	*3/4" MPT
SC042	H	47.1	20.1	21.0	52.0	34.0	27.0	2.0	1.6	16.8	1.6	3/4"	3.4	0.8	*3/4" MPT
	V	26.0	21.6	45.0	31.8	27.3	51.0	3.7	1.5	9.8	1.5	3/4"	20.7	1.4	*3/4" MPT
SC048	H	54.1	24.1	21.0	58.5	38.0	27.0	2.0	1.5	16.8	1.5	1"	3.4	0.8	*3/4" MPT
	V	29.3	25.5	50.5	36.0	31.0	56.5	3.7	2.0	11.1	2.0	1"	22.1	1.4	*3/4" MPT
SC060	H	54.1	24.1	21.0	58.5	38.0	27.0	2.0	1.5	17.4	1.5	1"	3.4	0.8	*3/4" MPT
	V	29.3	25.5	50.5	36.0	31.0	56.5	3.7	2.0	11.1	2.0	1"	22.1	1.4	*3/4" MPT
SC041	V	21.5	21.6	40.0	27.3	27.3	46.0	3.7	1.5	9.8	1.5	3/4"	19.7	1.4	*3/4" MPT
	F	21.5	21.6	40.0	27.3	27.3	46.0	3.8	1.9	9.8	1.9	3/4"	19.7	1.6	*3/4" MPT

*See PDF drawings for reference.

Dimensional Data

Models:
SC
006-060

Discharge Connection Duct Flange, Return Connection, Hanger, and Electrical Knockout Dimensions (in)

Model	Cabinet Config.	Discharge Connection Duct Flange Installed				Return Connection Using Return Air Opening				Unit Hanger Detail			Electrical Knockouts			
		Supply Height	Supply Width	O	P	Return Width	Return Height	S	T	U	V	W	H	Low Voltage	High Voltage	G
		M	N			Q	R							J KO 1/2"	K KO 3/4"	
SC006	H	8.9	6.6	6.0	1.3	16.1	9.0	1.2	1.0	34.1	21.3	16.9	3.6	5.9	8.9	1.1
	V	9.0	9.0	8.9	5.0	16.1	9.0	2.1	1.0				3.6	5.9	8.1	1.1
SC009	H	8.9	6.6	6.0	1.3	16.1	9.0	1.2	1.0	34.1	21.3	16.9	3.6	5.9	8.9	1.1
	V	9.0	9.0	8.9	5.0	16.1	9.0	2.1	1.0				3.6	5.9	8.1	1.1
	F	9.0	9.0	4.4	5.5	16.1	9.0	2.1	1.0				3.6	5.9	8.1	1.1
SC012	H	8.9	6.6	6.0	1.3	16.1	9.0	1.2	1.0	34.1	21.3	16.9	3.6	5.9	8.9	1.1
	V	9.0	9.0	8.9	5.0	16.1	9.0	2.1	1.0				3.6	5.9	8.1	1.1
	F	9.0	9.0	4.4	5.5	16.1	9.0	2.1	1.0				3.6	5.9	8.1	1.1
SC015	H	13.1	9.6	3.9	1.2	23.0	15.0	1.1	1.0	43.0	22.1	17.9	4.1	7.1	14.1	1.3
	V	14.0	14.0	6.6	3.8	18.4	18.2	2.3	1.0				4.1	7.1	15.1	1.3
	F	14.0	14.0	5.7	3.8	18.9	19.1	2.0	1.0				4.1	7.1	15.1	1.3
SC018	H	13.1	9.6	3.9	1.2	23.0	15.0	1.1	1.0	43.0	22.1	17.9	4.1	7.1	14.1	1.3
	V	14.0	14.0	6.6	3.8	18.4	18.2	2.3	1.0				4.1	7.1	15.1	1.3
	F	14.0	14.0	5.7	3.8	18.9	19.1	2.0	1.0				4.1	7.1	15.1	1.3
SC024	H	13.1	9.6	3.9	1.2	22.9	16.3	1.1	1.0	43.0	22.1	17.9	4.1	7.1	14.1	1.3
	V	14.0	14.0	6.6	3.7	18.4	18.3	2.3	1.0				4.1	7.1	15.1	1.3
	F	14.0	14.0	3.8	5.7	18.0	19.1	2.1	1.0				4.1	7.1	15.1	1.3
SC030	H	13.1	9.6	3.9	1.2	22.9	16.3	1.1	1.0	43.0	22.1	17.9	4.1	7.1	14.1	1.3
	V	14.0	14.0	6.6	3.7	18.4	18.3	2.3	1.0				4.1	7.1	15.1	1.3
	F	14.0	14.0	3.8	5.7	18.0	19.1	2.1	1.0				4.1	7.1	15.1	1.3
SC036	H	16.1	10.9	3.0	2.5	25.9	19.0	1.1	1.0	47.0	22.6	17.9	4.1	7.1	17.1	1.3
	V	14.0	14.0	6.6	6.0	22.9	22.2	2.3	1.0				4.1	7.1	15.8	1.3
SC042	H	16.1	10.9	3.0	2.5	25.9	19.0	1.1	1.0	47.0	22.6	17.9	4.1	7.1	17.1	1.3
	V	14.0	14.0	6.6	6.0	22.9	22.2	2.3	1.0				4.1	7.1	15.8	1.3
SC048	H	15.9	13.5	4.1	1.2	35.9	19.0	1.1	1.0	54.0	26.2	21.9	4.1	7.1	17.1	1.3
	V	18.0	16.0	8.4	5.6	26.2	26.3	2.4	1.0				4.1	7.1	16.7	1.3
SC060	H	18.1	13.3	4.2	1.1	36.9	19.0	1.1	1.0	54.0	26.2	21.9	4.1	7.1	17.1	1.3
	V	18.0	16.0	8.5	5.6	26.2	26.3	2.4	1.0				4.1	7.1	16.7	1.3
SC041	V	14.0	14.0	6.3	4.8	18.4	18.3	2.3	1.0				4.1	7.1	15.1	1.3
	F	14.0	14.0	5.7	3.8	18.0	19.1	2.1	1.0				4.1	7.1	15.1	1.3

ClimateMaster works continually to improve its products. As a result, the design and specifications of each product at the time of order may be changed without notice and may not be as described herein. Please contact ClimateMaster's Customer Service Department at 800-299-9747 for specific information on the current design and specifications. Statements and other information contained herein are not express warranties and do not form the basis of any bargain between the parties, but are merely ClimateMaster's opinion or commendation of its products. The latest version of this document is available at www.climatemaster.com. Engineered and assembled in the USA. © ClimateMaster, Inc. All Rights Reserved 2024

Dimensional Data

Models:
SC
006-060

Cabinet, Shipping, Water Connections, and Condensate Drain Pan Dimensions (cm)

Model	Cabinet Config.	Overall Cabinet			Shipping Overall Dimensions			Water Connections					Condensate Drain Pan		
		Depth/Length	Width	Height	Depth/Length	Width	Height	Water In		Water Out		Water In/Out	AA	BB	Condensate Drain Pan Fitting
		A	B	C	A	B	C	D	E	F	E				
SC006	H	86.6	48.5	27.9	101.6	63.8	43.2	14.5	2.5	24.6	2.5	1/2"	1.8	8.4	*3/4" MPT
	V	48.3	48.5	55.9	62.9	62.9	71.1	4.3	4.3	24.6	4.3	1/2"	29.7	3.8	*3/4" MPT
SC009	H	86.6	48.5	27.9	101.6	63.8	43.2	14.5	2.5	24.6	2.5	1/2"	1.8	8.4	*3/4" MPT
	V	48.3	48.5	55.9	62.9	62.9	71.1	4.3	4.3	24.6	4.3	1/2"	29.7	3.8	*3/4" MPT
	F	48.3	48.5	55.9	62.9	62.9	71.1	4.3	4.6	24.6	4.6	1/2"	29.7	3.8	*3/4" MPT
SC012	H	86.6	48.5	27.9	101.6	63.8	43.2	14.5	2.5	24.6	2.5	1/2"	1.8	8.4	*3/4" MPT
	V	48.3	48.5	55.9	62.9	62.9	71.1	4.3	4.3	24.6	4.3	1/2"	29.7	3.8	*3/4" MPT
	F	48.3	48.5	55.9	62.9	62.9	71.1	4.3	4.6	24.6	4.6	1/2"	29.7	3.8	*3/4" MPT
SC015	H	109.2	51.1	43.2	123.2	85.1	58.4	8.9	3.8	35.1	3.8	1/2"	2.5	8.6	*3/4" MPT
	V	54.6	54.9	101.6	69.2	69.2	116.8	9.4	3.8	24.6	3.8	1/2"	50.0	3.8	*3/4" MPT
	F	54.6	54.9	101.6	69.2	69.2	116.8	9.4	4.8	24.6	4.8	1/2"	50.0	3.8	*3/4" MPT
SC018	H	109.2	51.1	43.2	123.2	85.1	58.4	8.9	3.8	35.1	3.8	1/2"	2.5	8.6	*3/4" MPT
	V	54.6	54.9	101.6	69.2	69.2	116.8	9.4	3.8	24.6	3.8	1/2"	50.0	3.8	*3/4" MPT
	F	54.6	54.9	101.6	69.2	69.2	116.8	9.4	4.8	24.6	4.8	1/2"	50.0	3.8	*3/4" MPT
SC024	H	109.3	51.1	46.4	123.2	85.1	61.6	5.1	3.8	39.1	3.8	3/4"	8.8	2.0	*3/4" MPT
	V	54.7	54.9	101.7	69.2	69.2	116.9	9.5	3.9	24.8	3.9	3/4"	50.1	3.8	*3/4" MPT
	F	54.7	54.9	101.7	69.2	69.2	116.9	9.6	4.9	24.8	4.9	3/4"	50.1	3.8	*3/4" MPT
SC030	H	109.3	51.1	46.4	123.2	85.1	61.6	5.1	3.8	39.1	3.8	3/4"	8.8	2.0	*3/4" MPT
	V	54.7	54.9	101.7	69.2	69.2	116.9	9.5	3.9	24.8	3.9	3/4"	50.1	3.8	*3/4" MPT
	F	54.7	54.9	101.7	69.2	69.2	116.9	9.6	4.9	24.8	4.9	3/4"	50.1	3.8	*3/4" MPT
SC036	H	119.5	51.1	53.3	132.1	86.4	68.6	5.1	4.0	42.5	4.0	3/4"	8.7	2.1	*3/4" MPT
	V	66.2	54.8	114.3	80.6	69.2	129.5	9.5	3.8	24.8	3.8	3/4"	52.5	3.7	*3/4" MPT
SC042	H	119.5	51.1	53.3	132.1	86.4	68.6	5.1	4.0	42.5	4.0	3/4"	8.7	2.1	*3/4" MPT
	V	66.2	54.8	114.3	80.6	69.2	129.5	9.5	3.8	24.8	3.8	3/4"	52.5	3.7	*3/4" MPT
SC048	H	137.3	61.2	53.3	148.6	96.5	68.6	5.1	3.8	42.5	3.8	1"	8.7	2.1	*3/4" MPT
	V	74.5	64.7	128.3	91.4	78.7	143.5	9.5	5.1	28.1	5.1	1"	56.2	3.7	*3/4" MPT
SC060	H	137.3	61.2	53.3	148.6	96.5	68.6	5.1	3.8	44.1	3.8	1"	8.7	2.1	*3/4" MPT
	V	74.5	64.7	128.3	91.4	78.7	143.5	9.5	5.1	28.1	5.1	1"	56.2	3.7	*3/4" MPT
SC041	V	54.7	54.9	101.7	69.2	69.2	116.9	9.5	3.9	24.8	3.9	3/4"	50.1	3.7	*3/4" MPT
	F	54.7	54.9	101.7	69.2	69.2	116.9	9.6	4.9	24.8	4.9	3/4"	50.1	4.0	*3/4" MPT

*See PDF drawings for reference.

Discharge Connection Duct Flange, Return Connection, Hanger, and Electrical Knockout Dimensions (cm)

Model	Cabinet Config.	Discharge Connection Duct Flange Installed				Return Connection Using Return Air Opening				Unit Hanger Detail			Electrical Knockouts			
		Supply Height	Supply Width	O	P	Return Width	Return Height	S	T	U	V	W	H	Low Voltage	High Voltage	G
		M	N			Q	R							J KO 1/2"	K KO 3/4"	
SC006	H	22.6	16.8	15.2	3.3	40.9	22.9	3.0	2.5	86.6	54.1	42.9	9.1	15.0	22.6	2.8
	V	22.9	22.9	12.7	22.6	40.9	22.9	5.3	2.5				9.1	15.0	20.6	2.8
SC009	H	22.6	16.8	15.2	3.3	40.9	22.9	3.0	2.5	86.6	54.1	42.9	9.1	15.0	22.6	2.8
	V	22.9	22.9	12.7	22.6	40.9	22.9	5.3	2.5				9.1	15.0	20.6	2.8
	F	22.9	22.9	14.0	11.2	40.9	22.9	5.3	2.5				9.1	15.0	20.6	2.8
SC012	H	22.6	16.8	15.2	3.3	40.9	22.9	3.0	2.5	86.6	54.1	42.9	9.1	15.0	22.6	2.8
	V	22.9	22.9	12.7	22.6	40.9	22.9	5.3	2.5				9.1	15.0	20.6	2.8
	F	22.9	22.9	14.0	11.2	40.9	22.9	5.3	2.5				9.1	15.0	20.6	2.8
SC015	H	33.3	24.4	9.9	3.0	58.4	38.1	2.8	2.5	109.2	56.1	45.5	10.4	18.0	35.8	3.3
	V	35.6	35.6	9.7	16.8	46.7	46.2	5.8	2.5				10.4	18.0	38.4	3.3
	F	35.6	35.6	14.5	9.7	48.0	48.5	5.1	2.5				10.4	18.0	38.4	3.3
SC018	H	33.3	24.4	9.9	3.0	58.4	38.1	2.8	2.5	109.2	56.1	45.5	10.4	18.0	35.8	3.3
	V	35.6	35.6	9.7	16.8	46.7	46.2	5.8	2.5				10.4	18.0	38.4	3.3
	F	35.6	35.6	14.5	9.7	48.0	48.5	5.1	2.5				10.4	18.0	38.4	3.3
SC024	H	24.5	33.3	10.0	3.0	58.3	41.3	2.8	2.5	109.3	56.2	45.6	10.5	18.1	35.9	3.2
	V	35.6	35.5	16.8	9.5	46.8	46.4	5.9	2.5				10.5	18.1	38.4	3.2
	F	35.6	35.5	14.4	9.6	45.8	48.5	5.3	2.5				10.5	18.1	38.4	3.2
SC030	H	24.5	33.3	10.0	3.0	58.3	41.3	2.8	2.5	109.3	56.2	45.6	10.5	18.1	35.9	3.2
	V	35.6	35.5	16.8	9.5	46.8	46.4	5.9	2.5				10.5	18.1	38.4	3.2
	F	35.6	35.5	9.6	14.4	45.8	48.5	5.3	2.5				10.5	18.1	38.4	3.4
SC036	H	27.8	40.9	7.5	6.2	65.9	48.3	2.8	2.5	119.5	57.5	45.6	10.5	18.1	43.5	3.2
	V	35.6	35.5	16.8	15.3	58.2	56.4	5.9	2.5				10.5	18.1	40.1	3.2
SC042	H	27.8	40.9	7.5	6.2	65.9	48.3	2.8	2.5	119.5	57.5	45.6	10.5	18.1	43.5	3.2
	V	35.6	35.5	16.8	15.3	58.2	56.4	5.9	2.5				10.5	18.1	40.1	3.2
SC048	H	34.3	40.4	10.3	3.0	91.3	48.3	2.8	2.5	137.2	66.5	55.7	10.5	18.1	43.5	3.2
	V	45.7	40.6	21.3	14.3	66.5	66.8	6.0	2.5				10.5	18.1	42.4	3.2
SC060	H	33.9	45.9	10.6	2.8	93.8	48.3	2.8	2.5	137.2	66.5	55.7	10.5	18.1	43.5	3.2
	V	45.7	40.6	21.5	14.3	66.5	66.8	6.0	2.5				10.5	18.1	42.4	3.2
SC041	V	35.6	35.5	16.0	12.2	46.8	46.4	5.9	2.5				10.5	18.1	38.4	3.2
	F	35.6	35.5	14.4	9.6	45.8	48.5	5.3	2.5				10.5	18.1	38.4	3.2

ClimateMaster works continually to improve its products. As a result, the design and specifications of each product at the time of order may be changed without notice and may not be as described herein. Please contact ClimateMaster's Customer Service Department at 800-299-9747 for specific information on the current design and specifications. Statements and other information contained herein are not express warranties and do not form the basis of any bargain between the parties, but are merely ClimateMaster's opinion or commendation of its products. The latest version of this document is available at www.climatemaster.com. Engineered and assembled in the USA. © ClimateMaster, Inc. All Rights Reserved 2024

Corner Weights (lb)

Model	Left - Front	Right - Front	Left - Back	Right/Back
SC006	37.0	24.0	23.0	19.0
SC009	38.0	24.0	23.0	20.0
SC012	42.0	26.0	25.0	21.0
SC015	53.0	36.0	34.0	30.0
SC018	55.0	37.0	35.0	31.0
SC024	62.0	40.0	39.0	33.0
SC030	67.0	41.0	40.0	34.0
SC036	75.0	47.0	44.0	37.0
SC042	81.0	50.0	48.0	39.0
SC048	98.0	60.0	58.0	47.0
SC060	94.0	59.0	56.0	69.0

Corner Weights (kg)

Model	Left - Front	Right - Front	Left - Back	Right/Back
SC006	16.8	10.9	10.4	8.6
SC009	17.2	10.9	10.4	9.1
SC012	19.1	11.8	11.3	9.5
SC015	24.0	16.3	15.4	13.6
SC018	24.9	16.8	15.9	14.1
SC024	28.1	18.1	17.7	15.0
SC030	30.4	18.6	18.1	15.4
SC036	34.0	21.3	20.0	16.8
SC042	36.7	22.7	21.8	17.7
SC048	44.5	27.2	26.3	21.3
SC060	42.6	26.8	25.4	31.3

Horizontal Dimensional Data

Models:
SC
006-060

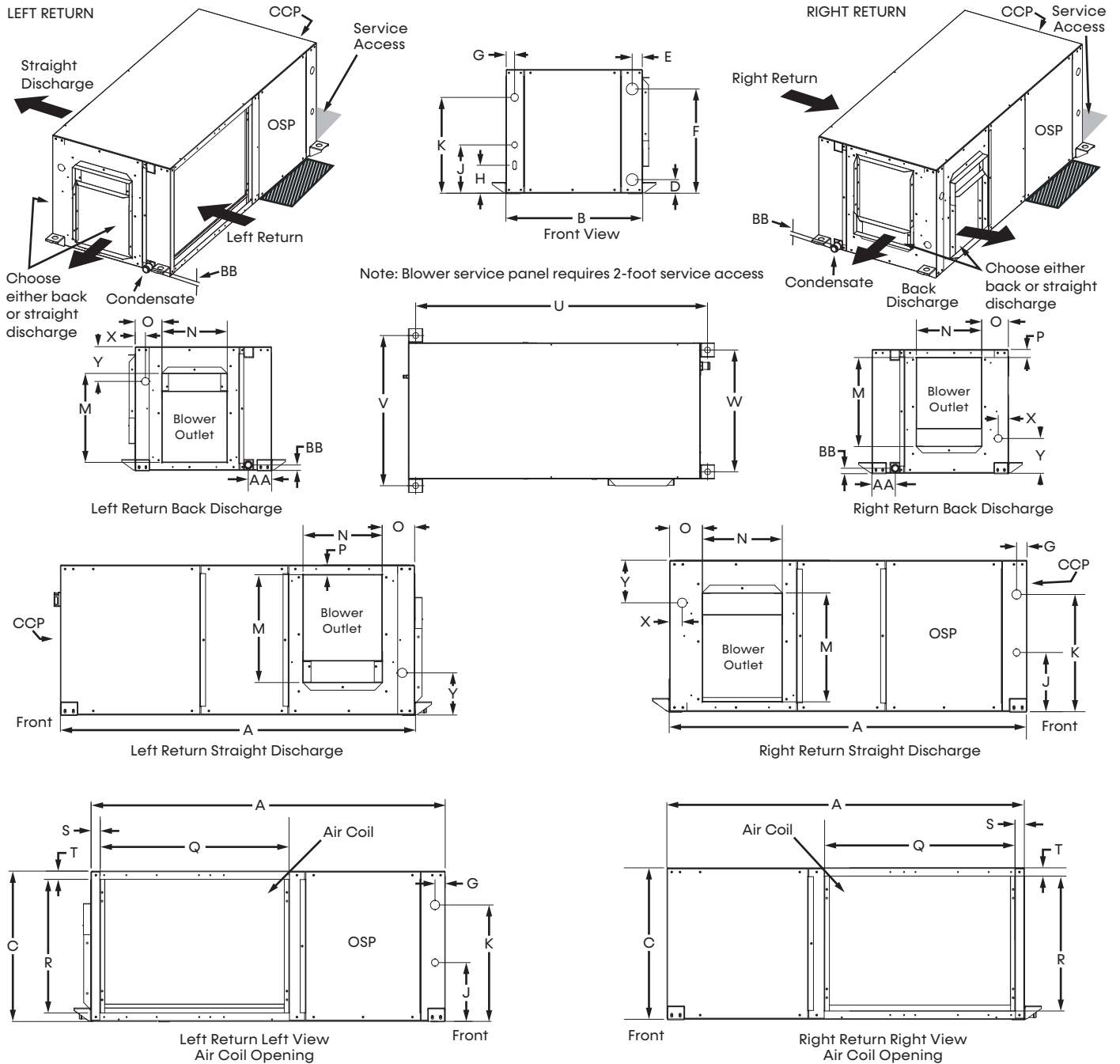

Notes:

1. While clear access to all removable panels is not required, installer should take care to comply with all building codes and allow adequate clearance for future field service.
2. Units come standard with air filter rails. For duct connections, order optional filter frames. See product options decoder for details. You can convert filter rails in the field with an accessory air filter frame kit. Please see the accessory submittal for details.
3. Discharge flange and hanger brackets are factory installed.
4. Condensate is a rubber coupling that couples to 3/4-inch schedule 40/80 PVC.
5. Blower service panel requires 2-foot service access.
6. Blower service access is through back panel on straight discharge units or through panel opposite air coil on back discharge units.
7. OSP are removable panels that provide additional access to the units interior. Clear access to OSP panels is not required and they are not to be used in place of the mandatory CCP and BSP panels.

Legend:

- CCP = Control/Compressor Access
- BSP = Blower Service Panel
- OSP = Optional Service Panel (not required)

ClimateMaster works continually to improve its products. As a result, the design and specifications of each product at the time of order may be changed without notice and may not be as described herein. Please contact ClimateMaster's Customer Service Department at 800-299-9747 for specific information on the current design and specifications. Statements and other information contained herein are not express warranties and do not form the basis of any bargain between the parties, but are merely ClimateMaster's opinion or commendation of its products. The latest version of this document is available at www.climatemaster.com. Engineered and assembled in the USA. © ClimateMaster, Inc. All Rights Reserved 2024

Horizontal Service Access

Models:
SC
006-060

Left Return Back Discharge

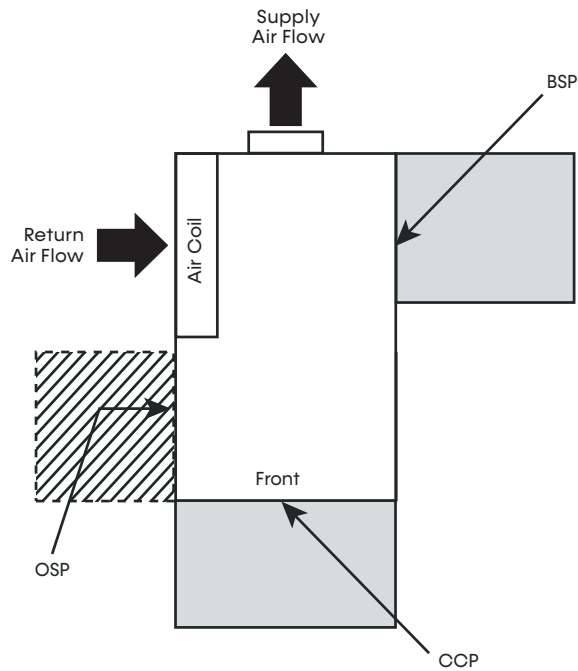

Right Return Back Discharge

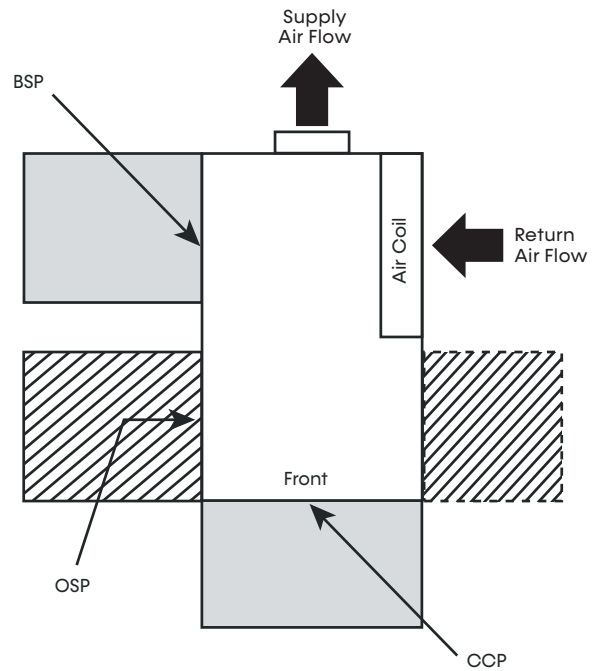

Left Return Straight Discharge

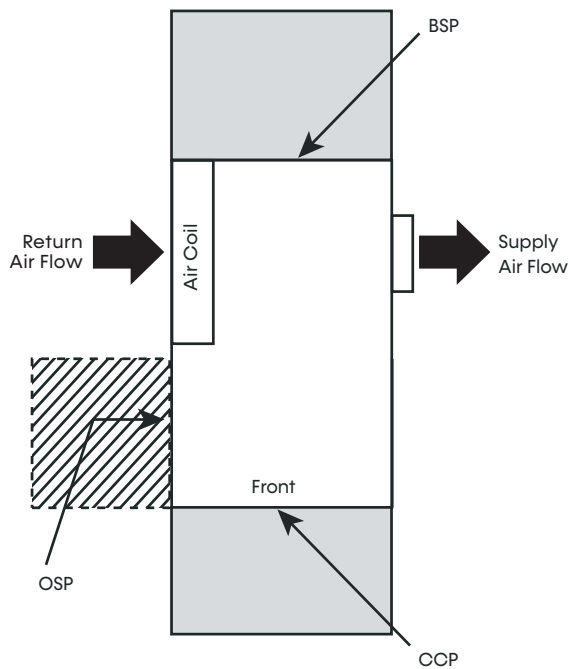

Right Return Straight Discharge

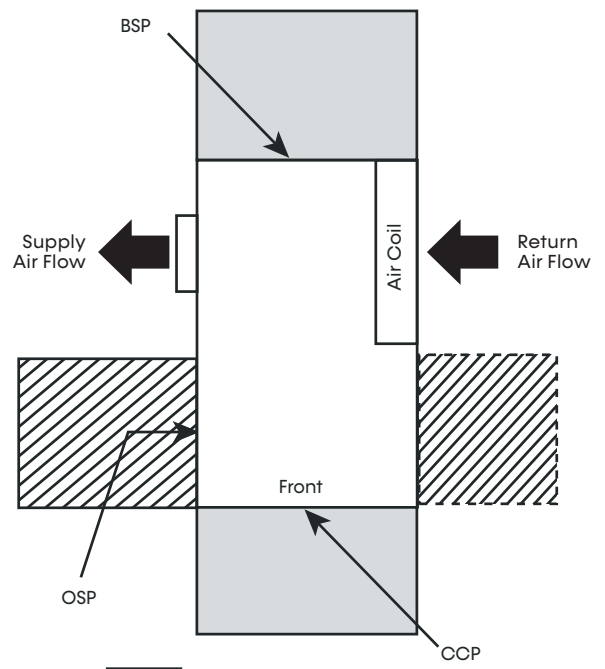

= Mandatory Service Access 2-foot (61 cm)

= Optional Service Access 2-foot (61 cm)

Notes:

1. While clear access to all removable panels is not required, installer should take care to comply with all building codes and allow adequate clearance for future field service.
2. CCP and BSP requires 2 feet of service access.
3. Blower service access is through back panel on straight discharge units or through panel opposite air coil on back discharge units.
4. OSP are removable panels that provide additional access to the units interior. Clear access to OSP panels is not required and they are not to be used in place of the mandatory CCP and BSP panels.

Legend:

- CCP = Control/Compressor Access
- BSP = Blower Service Panel
- OSP = Optional Service Panel (not required)

ClimateMaster works continually to improve its products. As a result, the design and specifications of each product at the time of order may be changed without notice and may not be as described herein. Please contact ClimateMaster's Customer Service Department at 800-299-9747 for specific information on the current design and specifications. Statements and other information contained herein are not express warranties and do not form the basis of any bargain between the parties, but are merely ClimateMaster's opinion or commendation of its products. The latest version of this document is available at www.climatemaster.com. Engineered and assembled in the USA. © ClimateMaster, Inc. All Rights Reserved 2024

Vertical Upflow Dimensional Data

Models:
SC
006-060

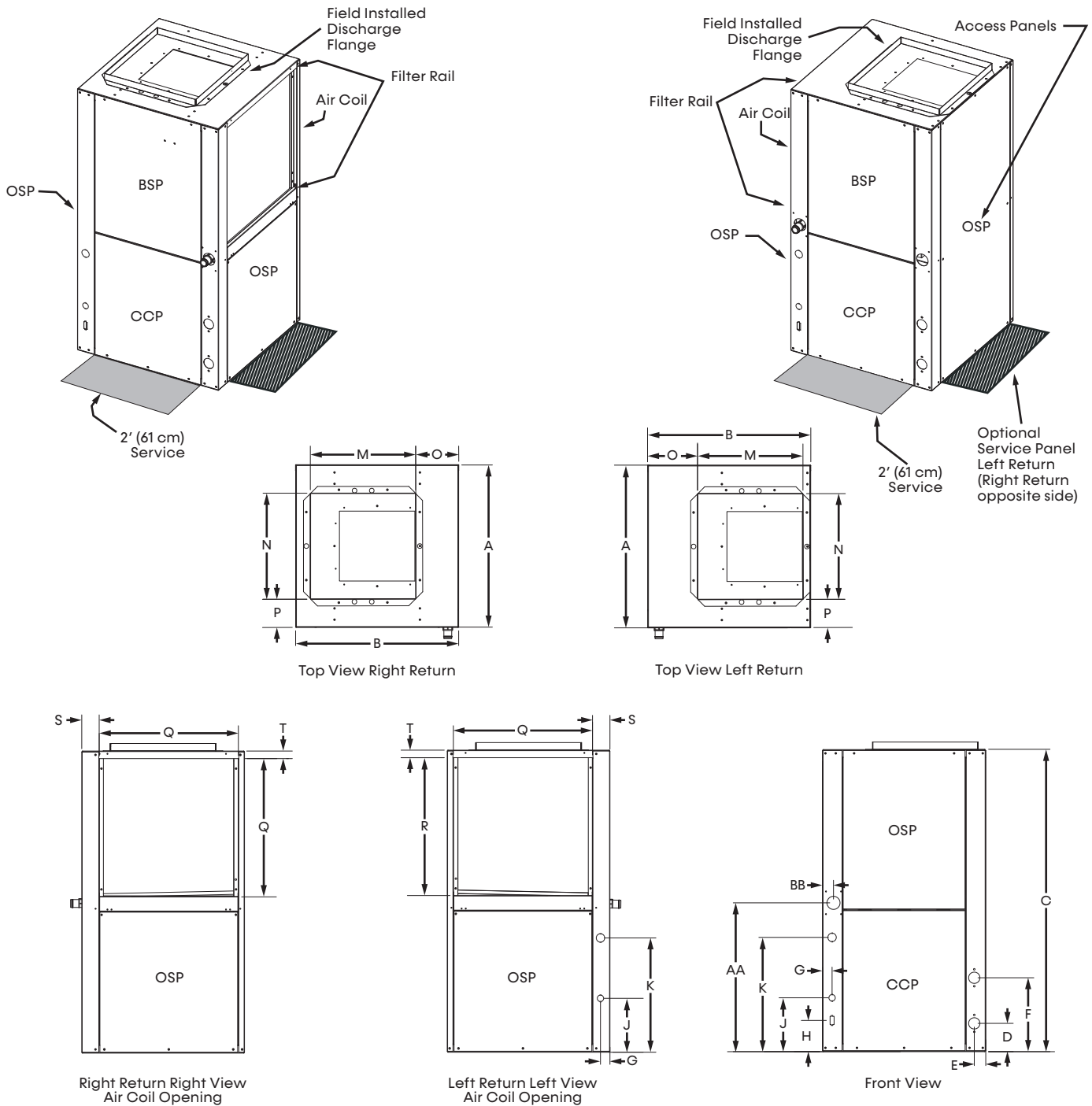

Notes:

1. While clear access to all removable panels is not required, installer should take care to comply with all building codes and allow adequate clearance for future field service. Front and side access is preferred for service access. However, all components may be serviced from the front access panel if side access is not available. (Except on vertical sizes 024-030). Units with the front return require left-side access for the fan.
2. Discharge flange is field installed.
3. Condensate fitting on polymer drain pan is rubber coupling that couples to 3/4-inch schedule 40/80 PVC, S.S. drain pan is 3/4-inch MPT.
4. Units are shipped with air filter rails that are not suitable for supporting return air ductwork. An air filter frame with duct mounting collar is available as an accessory, see the Accessory Submittal set for further information on this frame.

Legend:

- CCP = Control/Compressor Access
- BSP = Blower Service Panel
- OSP = Optional Service Panel (not required)

ClimateMaster works continually to improve its products. As a result, the design and specifications of each product at the time of order may be changed without notice and may not be as described herein. Please contact ClimateMaster's Customer Service Department at 800-299-9747 for specific information on the current design and specifications. Statements and other information contained herein are not express warranties and do not form the basis of any bargain between the parties, but are merely ClimateMaster's opinion or commendation of its products. The latest version of this document is available at www.climatemaster.com. Engineered and assembled in the USA. © ClimateMaster, Inc. All Rights Reserved 2024

Vertical Upflow Front Return Dimensional Data

Models:
SC
006-060

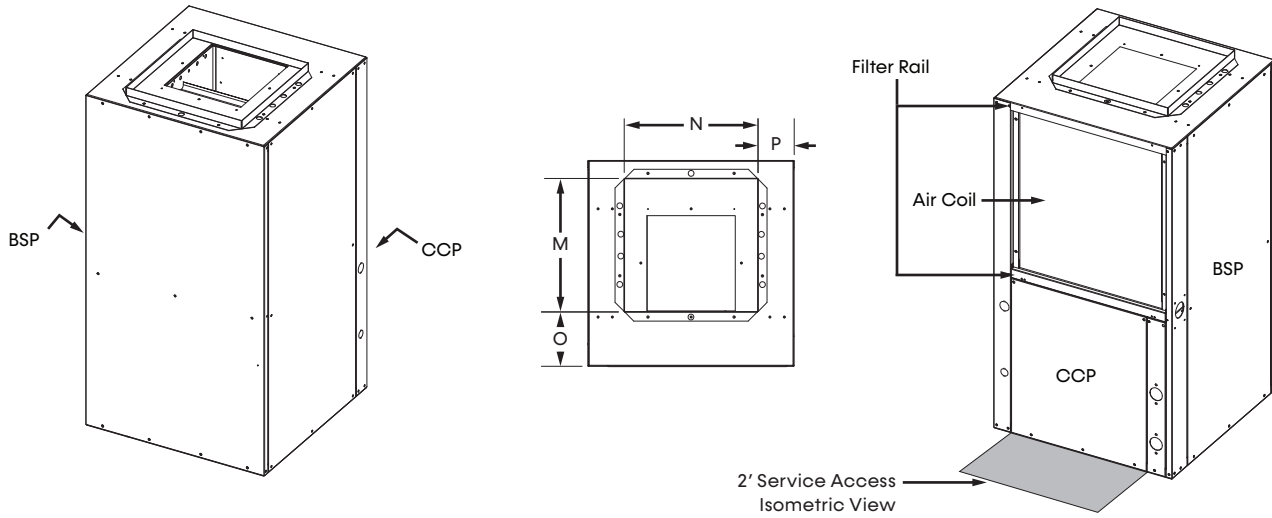

Either Left or Right panel must have 2' of accessibility for Blower Service Panel

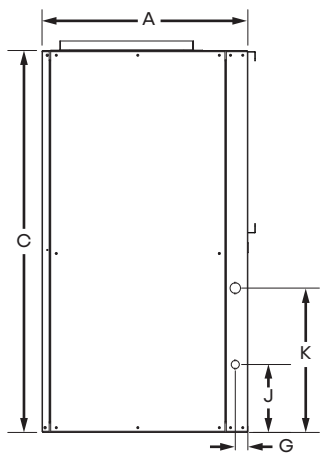

Left View

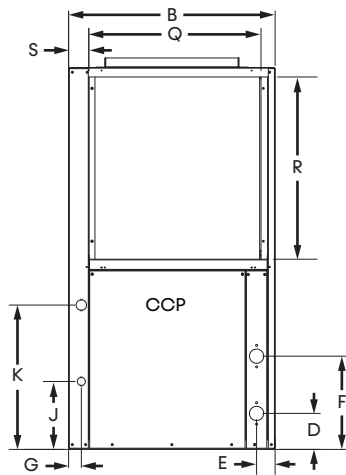

Front View

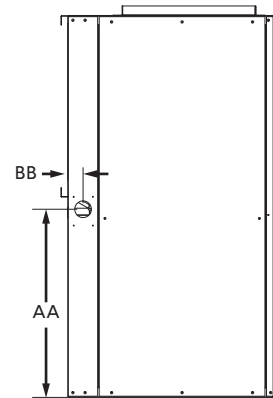

Right View

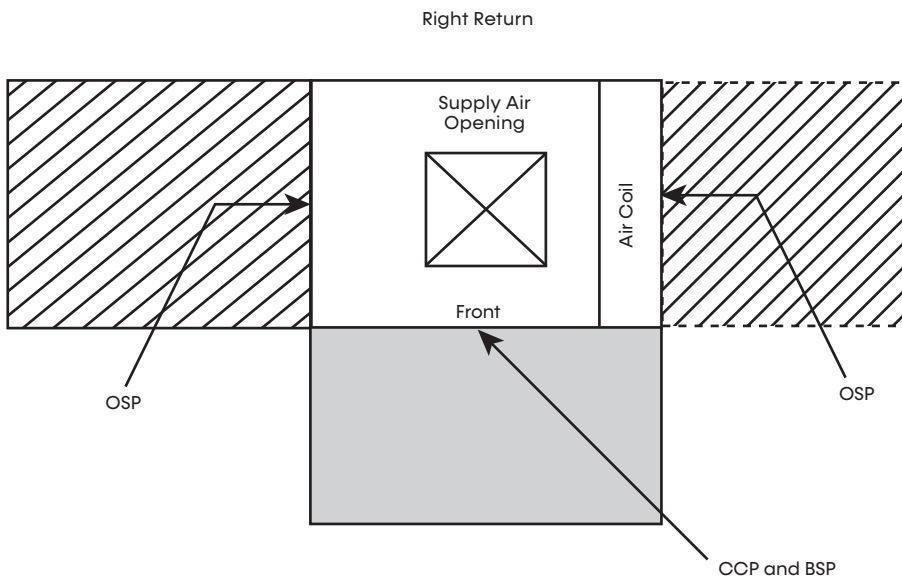
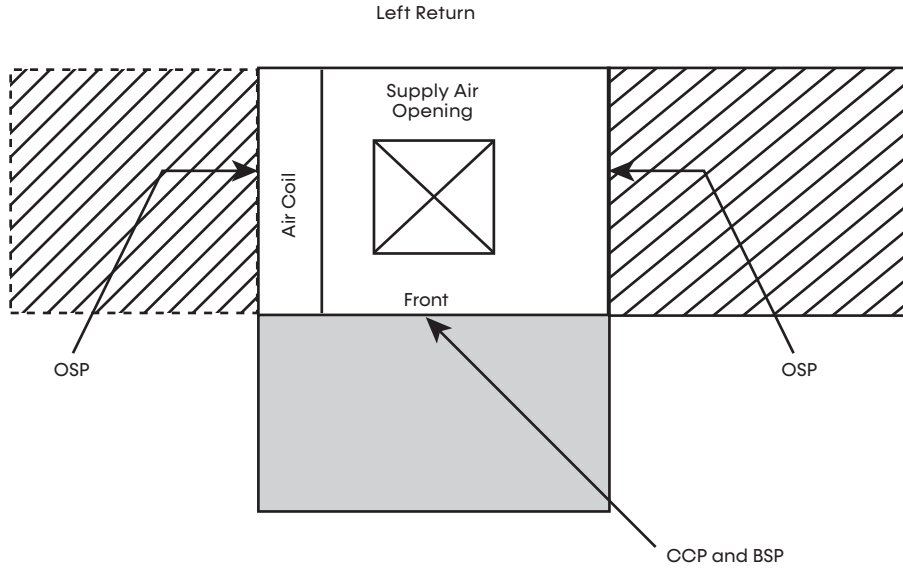

Vertical Service Access

Models:
SC
006-060



Notes:

1. While clear access to all removable panels is not required, installer should take care to comply with all building codes and allow adequate clearance for future field service.
2. Front and Side access is preferred for service access.
3. OSP are removable panels that provide additional access to the units interior. Clear access to OSP panels is not required and they are not to be used in place of the mandatory CCP and BSP panels.
4. Front return units (not shown) require front access for controls/compressor and left side access for blower.

-  = Mandatory Service Access 2-foot (61 cm)
-  = Optional Service Access 2-foot (61 cm)

Legend:

- CCP = Control/Compressor Access
- BSP = Blower Service Panel
- OSP = Additional Service Panel (not required)

ClimateMaster works continually to improve its products. As a result, the design and specifications of each product at the time of order may be changed without notice and may not be as described herein. Please contact ClimateMaster's Customer Service Department at 800-299-9747 for specific information on the current design and specifications. Statements and other information contained herein are not express warranties and do not form the basis of any bargain between the parties, but are merely ClimateMaster's opinion or commendation of its products. The latest version of this document is available at www.climatemaster.com. Engineered and assembled in the USA. © ClimateMaster, Inc. All Rights Reserved 2024

MINIMUM INSTALLATION AREA

Minimum area where a blower-equipped unit must be installed, and mechanical/natural ventilation is not required

Model	Charge (oz)	Configuration	Minimum Installation Area ft ² (m ²) [A _{min}]			
			Floor	Window	Wall	Ceiling
SC060	69	Vertical	237 (22.0)	132 (12.2)	76 (7.0)	63 (5.9)
		Horizontal	237 (22.0)	141 (13.1)	79 (7.3)	65 (3.0)

A _{min} =	Minimum area where unit is installed where unit has incorporated airflow
h _{inst} (floor) =	0.0 ft (0.0 m)
h _{inst} (window) =	3.3 ft (1.0 m)
h _{inst} (wall) =	5.9 ft (1.8 m)
h _{inst} (ceiling) =	7.2 ft (2.2 m)

Minimum area and CFM requirements for the conditioned space

Model	Charge (oz)	Minimum CFM [Q _{min}]	
		TA _{min} (ft ²)	Q _{min} (ft ³ /min)
SC060	69	3.54	117

TA _{min} =	Minimum conditioned area for venting leaked refrigerant
Q _{min} =	Minimum ventilation flow rate for conditioned space if space is less than TA _{min}

Minimum area of opening for natural ventilation

Model	Charge (oz)	Anv _{min} in ² (m ²)
SC060	69	111.57 (0.07)

Anv _{min} =	Minimum natural ventilation area opening
----------------------	--

When the openings for connected rooms or natural ventilation are required, the following conditions shall be applied:

- The area of any openings above 11.8 inches (300 mm) from the floor shall not be considered in determining compliance with Anv_{min}.
- At least 50% of the required opening area Anv_{min} shall be below 7.8 inches (200 mm) from the floor.
- The bottom of the lowest openings shall not be higher than the point of release when the unit is installed and not more than 3.9 inches (100 mm) from the floor.
- Openings are permanent openings which cannot be closed.
- For openings extending to the floor, the height shall not be less than 0.78 inch (20 mm) above the surface of the floor covering.
- A second higher opening shall be provided. The total size of the second opening shall not be less than 50% of minimum opening area for Anv_{min} and shall be at least 3.3 ft (1.5 m) above the floor.

Electrical Data PSC Blower Motor Standard Unit

Models:
SC
006-060

Model	VOLTAGE CODE	RATED VOLTAGE	VOLTAGE MIN/MAX	COMPRESSOR			FAN MOTOR FLA	TOTAL UNIT FLA	MIN CIRCUIT AMP	MAX FUSE/HACR
				QTY	RLA	LRA				
SC006	G.J.	208/230-1-60	187/252	1	3.7	17.7	0.3	4.0	4.9	15
	E.D.	265-1-60	249/291	1	2.6	10.5	0.4	3.0	3.7	15
SC009	G.J.	208/230-1-60	187/252	1	5.0	22.2	0.8	5.8	7.1	15
	E.D.	265-1-60	249/291	1	3.6	13.5	0.8	4.4	5.3	15
SC012	G.J.	208/230-1-60	187/252	1	5.6	32.5	0.8	6.4	7.8	15
	E.D.	265-1-60	249/291	1	4.2	23.0	0.8	5.0	6.1	15
SC015	G.J.	208/230-1-60	187/252	1	6.6	31.0	0.9	7.5	9.2	15
	E.D.	265-1-60	249/291	1	5.0	27.0	0.7	5.7	7.0	15
SC018	G.J.	208/230-1-60	187/252	1	7.0	35.0	0.9	7.9	9.7	15
	E.D.	265-1-60	249/291	1	6.5	40.0	0.7	7.2	8.8	15
SC024	G.J.	208/230-1-60	187/252	1	11.4	64.4	1.5	12.9	15.8	25
	E.D.	265-1-60	249/291	1	10.3	60.5	1.2	11.5	14.1	20
	H.K.	208/230-3-60	187/252	1	7.7	59.9	1.5	9.2	11.1	15
	F.L.	460-3-60	432/504	1	3.8	32.4	0.8	4.6	5.5	15
SC030	G.J.	208/230-1-60	187/252	1	12.7	75.6	2.7	15.4	18.6	30
	E.D.	265-1-60	249/291	1	11.5	84.0	2.9	14.4	17.3	25
	H.K.	208/230-3-60	187/252	1	9.6	67.7	2.7	12.3	14.7	20
	F.L.	460-3-60	432/504	1	4.5	38.1	1.6	6.1	7.2	15
SC036	G.J.	208/230-1-60	187/252	1	14.4	86.0	2.6	17.0	20.6	35
	E.D.	265-1-60	249/291	1	10.2	55.0	2.0	12.2	14.8	25
	H.K.	208/230-3-60	187/252	1	9.0	70.0	2.6	11.6	13.9	20
	F.L.	460-3-60	432/504	1	4.1	39.0	1.2	5.3	6.3	15
SC042	G.J.	208/230-1-60	187/252	1	17.3	123.0	2.7	20.0	24.3	40
	H.K.	208/230-3-60	187/252	1	12.8	102.8	2.7	15.5	18.7	30
	F.L.	460-3-60	432/504	1	5.8	48.5	1.6	7.4	8.9	15
	N.M.	575-3-60	540/630	1	5.1	41.0	1.4	6.5	7.8	15
SC048	G.J.	208/230-1-60	187/252	1	22.4	126.0	3.3	25.7	31.3	50
	H.K.	208/230-3-60	187/252	1	12.8	120.4	3.3	16.1	19.3	30
	F.L.	460-3-60	432/504	1	6.0	49.4	1.7	7.7	9.2	15
	N.M.	575-3-60	540/630	1	5.8	41.0	1.4	7.2	8.7	15
SC060	G.J.	208/230-1-60	187/252	1	23.7	157.0	4.8	28.5	34.4	50
	H.K.	208/230-3-60	187/252	1	16.0	156.4	4.8	20.8	24.8	40
	F.L.	460-3-60	432/504	1	7.1	69.0	2.4	9.5	11.3	15
	N.M.	575-3-60	540/630	1	6.4	48.0	1.8	8.2	9.8	15
SC041	G.J.	208/230-1-60	187/252	1	16.7	93.5	2.7	19.4	23.6	40
	H.K.	208/230-3-60	187/252	1	12.2	97.5	2.7	14.9	18.0	30
	F.L.	460-3-60	432/504	1	5.8	44.3	1.6	7.4	8.9	15
	N.M.	575-3-60	540/630	1	4.5	27.1	1.4	5.9	7.0	15

Notes:
 • All fuses Class RK-5.

Electrical Data EC Blower Motor Standard Unit

Models:
SC
006-060

Model	VOLTAGE CODE	SC Electrical Table					CT EC				CV EC*			
		VOLTAGE	VOLTAGE MIN/MAX	COMPRESSOR			FAN MOTOR FLA	TOTAL UNIT FLA	MIN CIRCUIT AMP	FUSE/HACR AMP	FAN MOTOR FLA	TOTAL UNIT FLA	MIN CIRCUIT AMP	FUSE/HACR AMP
				QTY	RLA	LRA								
SC006	G.J.	208/230-1-60	187/252	1	3.7	17.7	2.3	6.0	6.9	15	1.5	5.2	6.1	15
	E.D.	265-1-60	249/291	1	2.6	10.5	2.3	4.9	5.6	15	1.4	4.0	4.7	15
SC009	G.J.	208/230-1-60	187/252	1	5.0	22.2	2.3	7.3	8.6	15	1.5	6.5	7.8	15
	E.D.	265-1-60	249/291	1	3.6	13.5	2.3	5.9	6.8	15	1.4	5.0	5.9	15
SC012	G.J.	208/230-1-60	187/252	1	5.6	32.5	2.3	7.9	9.3	15	2.6	8.2	9.6	15
	E.D.	265-1-60	249/291	1	4.2	23.0	2.3	6.5	7.6	15	2.5	6.7	7.8	15
SC015	G.J.	208/230-1-60	187/252	1	6.6	31.0	2.6	9.2	10.9	15	2.6	9.2	10.9	15
	E.D.	265-1-60	249/291	1	5.0	27.0	1.9	6.9	8.2	15	2.4	7.4	8.7	15
SC018	G.J.	208/230-1-60	187/252	1	7.0	35.0	2.6	9.6	11.4	15	2.6	9.6	11.4	15
	E.D.	265-1-60	249/291	1	6.5	40.0	1.9	8.4	10.0	15	2.1	8.6	10.2	15
SC024	G.J.	208/230-1-60	187/252	1	11.4	64.4	3.9	15.3	18.2	25	4.2	15.6	18.5	25
	E.D.	265-1-60	249/291	1	10.3	60.5	3.7	14.0	16.6	25	3.4	13.7	16.3	25
	H.K.	208/230-3-60	187/252	1	7.7	59.9	3.9	11.6	13.5	20	4.2	11.9	13.8	20
	F.L.	460-3-60*	432/504	1	3.8	32.4	1.2	5.0	6.0	15	3.4	7.2	8.2	15
SC030	G.J.	208/230-1-60	187/252	1	12.7	75.6	3.9	16.6	19.8	30	4.2	16.9	20.1	30
	E.D.	265-1-60	249/291	1	11.5	84.0	3.7	15.2	18.1	25	3.4	14.9	17.8	25
	H.K.	208/230-3-60	187/252	1	9.6	67.7	3.9	13.5	15.9	25	4.2	13.8	16.2	25
	F.L.	460-3-60*	432/504	1	4.5	38.1	1.2	5.7	6.8	15	3.4	7.9	9.0	15
SC036	G.J.	208/230-1-60	187/252	1	14.4	86.0	6.0	20.4	24.0	35	5.9	20.3	23.9	35
	E.D.	265-1-60	249/291	1	10.2	55.0	5.2	15.4	18.0	25	4.8	15.0	17.6	25
	H.K.	208/230-3-60	187/252	1	9.0	70.0	6.0	15.0	17.3	25	5.9	14.9	17.2	25
	F.L.	460-3-60*	432/504	1	4.1	39.0	1.7	5.8	6.8	15	4.8	8.9	9.9	15
SC042	G.J.	208/230-1-60	187/252	1	17.3	123.0	6.0	23.3	27.6	40	5.9	23.2	27.5	40
	H.K.	208/230-3-60	187/252	1	12.8	102.8	6.0	18.8	22.0	30	5.9	18.7	21.9	30
	F.L.	460-3-60*	432/504	1	5.8	48.5	1.7	7.5	9.0	15	4.8	10.6	12.1	15
SC048	G.J.	208/230-1-60	187/252	1	22.4	126.0	6.0	28.4	34.0	50	5.9	28.3	33.9	50
	H.K.	208/230-3-60	187/252	1	12.8	120.4	6.0	18.8	22.0	30	5.9	18.7	21.9	30
	F.L.	460-3-60*	432/504	1	6.0	49.4	1.7	7.7	9.2	15	4.8	10.8	12.3	15
SC060	G.J.	208/230-1-60	187/252	1	23.7	157.0	7.4	31.1	37.0	60	7.5	31.2	37.1	60
	H.K.	208/230-3-60	187/252	1	16.0	156.4	7.4	23.4	27.4	40	7.5	23.5	27.5	40
	F.L.	460-3-60*	432/504	1	7.1	69.0	2.3	9.4	11.2	15	6.2	13.3	15.1	20

Notes:

- All fuses Class RK-5

***Neutral connection required! All F and L voltage (460VAC) units with a CV EC motor require a four-wire power supply with neutral. The CV EC motor is rated 265VAC and is wired between one hot leg and neutral.**

GENERAL

Furnish and install ClimateMaster Tranquility® SC Water Source Heat Pumps, as indicated on the plans. Equipment shall be completely assembled, piped and internally wired. Capacities and characteristics as listed in the schedule and the specifications that follow.

Units shall be supplied completely factory built capable of operating over an entering water temperature range from 20° to 120°F (-6.7° to 48.9°C) as standard. Equivalent units from other manufacturers may be proposed provided approval to bid is given 10 days prior to bid closing. All equipment listed in this section must be rated and certified in accordance with Air-Conditioning, Heating and Refrigeration Institute/International Standards Organization (AHRI/ISO 13256-1). All equipment must be tested, investigated, and determined to comply with the requirements of the standards for Heating and Cooling Equipment UL 60335-2-40 4th Edition, UL 60335-1 6th Edition for the United States and Can/CSA C22.2 No. 60335-2-40:22, CAN/CSA C22.2 No 60335-1:16 for Canada, by Intertek Testing Laboratories (ETL). The units shall have AHRI/ISO and ETL-US-C labels.

All units shall pass a factory acceptance test. The quality control system shall automatically perform the factory acceptance test via computer. A detailed report card from the factory acceptance test shall be shipped with each unit. **Note: If a unit fails the factory acceptance test, it shall not be allowed to ship. Unit serial number will be recorded by factory acceptance test and furnished on report card for ease of unit warranty status.**

BASIC CONSTRUCTION

Horizontal units shall have one of the following air flow arrangements: Left Inlet/Straight (Right) Discharge; Right Inlet/Straight (Left) Discharge; Left Inlet/Back Discharge; or Right Inlet/Back Discharge as shown on the plans. Units must have the ability to be field convertible from straight to back or back to straight discharge with no additional parts or unit structure modification. Horizontal units will have factory installed hanger brackets with rubber isolation grommets packaged separately.

Vertical units shall have one of the following airflow arrangements: Left Return/Top Discharge, Right Return/Top Discharge, and Front Return/Top Discharge, as shown on the plans.

If units with these arrangements are not used, the contractor is responsible for any extra costs incurred by other trades. All units (horizontal and vertical) must have a minimum of two access panels for serviceability of compressor compartment. **Units having only one access panel to compressor/heat exchangers/expansion device/refrigerant piping shall not be acceptable.**

Compressor section interior surfaces shall be lined with ½-inch (12.7 mm) thick, 1-½ lb/ft³ (24 kg/m³) acoustic type glass fiber insulation. Air handling section interior surfaces shall be lined with ½-inch (12.7 mm) thick, 1-½ lb/ft³ (24 kg/m³) **foil-faced**, glass-fiber insulation for ease of cleaning. Insulation placement shall be designed in a manner that will eliminate any exposed edges to prevent the introduction of glass fibers into the air stream. **Units without foil-faced insulation in the air handling section will not be accepted.**

The heat pumps shall be fabricated from heavy gauge galvanized steel.

Standard insulation must meet NFPA Fire Hazard Classification requirements 25/50 per ASTM E84, UL 723, CAN/ULC S102-M88 and NFPA 90A requirements; air erosion and mold growth limits of UL-181; stringent fungal resistance test per ASTM-C1071 and ASTM G21; and shall meet zero level bacteria growth per ASTM G22. **Unit insulation must meet these stringent requirements or unit(s) will not be accepted.**

All horizontal units to have factory installed 1-inch (25.4 mm) discharge air duct collars, 1 inch (25.4 mm) filter rails with 1-inch (25.4 mm) filters factory installed, and factory installed unit-mounting brackets. Vertical units to have field installed discharge air duct collar, shipped loose and 1-inch (25.4 mm) filter rails with 1-inch (25.4 mm) filters factory installed. **If units with these factory installed provisions are not used, the contractor is responsible for any extra costs to field install these provisions, and/or the extra costs for their subcontractor to install these provisions.**

All units must have an insulated panel separating the fan compartment from the compressor compartment. **Units with the compressor in the air stream are not acceptable.** Units shall have factory installed 1-inch (25.4 mm) wide filter rails for filter removal from either side. Units shall have a 1-inch (25.4 mm) thick throwaway type glass fiber filter.

The contractor shall purchase one spare set of filters and replace factory shipped filters on completion of startup. Filters shall be standard sizes. **If units utilize non-standard filter sizes, then the contractor shall provide 12 spare filters for each unit.**

Cabinets shall have separate holes and knockouts for entrance of line voltage and low voltage control wiring. All factory-installed wiring passing through factory knockouts and openings shall be protected from sheet metal edges at openings by plastic ferrules. Supply- and return-water connections shall be copper FPT fittings. All water connections and electrical knockouts must be in the compressor compartment corner post as to not interfere with the serviceability of unit. **Contractors shall be responsible for any extra costs involved in the installation of units that do not have this feature.** Contractors must ensure that units can be easily removed for servicing and coordinate locations of electrical conduit and lights with the electrical contractor.

Option: 2-inch (50.8 mm) filter frame with removable access door and 2-inch (50.8 mm) Glass Fiber throwaway filters on all units.

Option: The contractor shall install 1-inch or 2-inch MERV-rated pleated media disposable air filters on all units.

Option: UltraQuiet package shall consist of additional sound insulation applied to the base pan, removable panels, and blower housing.

Option: The unit shall be supplied with extended range insulation option, which adds closed cell insulation to internal water lines, and provides insulation on suction side refrigeration tubing including refrigerant-to-water heat exchanger.

BLOWER AND MOTOR ASSEMBLY

Blowers shall have inlet rings to allow removal of wheel and motor from one side without removing housing. Units shall have a direct-drive centrifugal fan. The fan motor shall be 3-speed (2-speed for 575V), permanently lubricated, PSC type, with internal thermal overload protection. Units supplied without permanently lubricated motors must provide external oilers for easy service. The fan motor on small and medium size units (006-042) shall be isolated from the fan housing by a torsionally flexible motor mounting system with rubber type grommets to inhibit vibration induced high noise levels associated with "hard wire belly band" motor mounting. The fan motor on larger units (048 and 060) shall be isolated with flexible rubber type isolation grommets only. The fan and motor assembly must be capable of overcoming the external static pressures as shown on the schedule. Airflow/Static pressure rating of the unit shall be based on a wet coil and a clean filter in place. **Ratings based on a dry coil, and/or no air filter shall NOT be acceptable.**

Option: Constant Torque (CT) EC motors (sizes 006 to 060): The CT EC fan motor maximizes efficiency over its static operating range and provides airflow adjustment with 4 or 5 speed taps. The fan motor shall be isolated from the housing by rubber grommets. The motor shall be permanently lubricated and have thermal overload protection.

Option: Constant Volume (CV) EC motors (sizes 006 to 060): CV EC variable speed ball bearing type motor. The CV EC fan motor shall provide a soft low noise fan start by ramping fan up to full selected speed over a 30 second period, and slowly ramp down fan at the end of each blower cycle, maintain constant CFM, maximize motor efficiency over its static operating range, and provide airflow adjustment in multiple CFM increments. The fan motor shall be isolated from the housing by rubber grommets. The motor shall be permanently lubricated and have thermal overload protection.

A special dehumidification mode shall be provided to allow lower airflows in cooling for better dehumidification. The dehumidification mode may be constant or automatic (humidistat controlled). Constant CFM EC motors without controlled ramp up and ramp down features, with constant CFM speed taps, or with no microprocessor controller are not acceptable.

REFRIGERANT CIRCUIT

All units shall contain an R-454B sealed refrigerant circuit including a high efficiency scroll or rotary compressor designed for heat pump operation, a thermostatic expansion valve for refrigerant metering, an enhanced corrugated aluminum lanced fin and rifled copper tube refrigerant-to-air heat exchanger, reversing valve, coaxial (tube-in-tube) refrigerant-to-water heat exchanger, and safety controls including a high-pressure switch, low-pressure (loss-of-charge) switch, water coil low-temperature sensor, and air coil low-temperature sensor. Access fittings shall be factory installed on high- and low-pressure refrigerant lines to facilitate field service. Activation of any safety device shall prevent compressor operation via a microprocessor lockout circuit. The lockout circuit shall be reset at the thermostat or at the contractor-supplied disconnect switch. **Units that cannot be reset at the thermostat shall not be acceptable.**

The compressor shall have a dual level vibration isolation system. The compressor will be mounted on specially engineered sound-tested EPDM vibration isolation grommets or springs to a large heavy gauge compressor mounting plate, which is then isolated from the cabinet base with EPDM grommets for maximized vibration attenuation. Compressors shall have thermal overload protection. Compressors shall be located in an insulated compartment away from air stream to minimize sound transmission.

Refrigerant to air heat exchangers shall utilize enhanced corrugated lanced aluminum fins and rifled copper tube construction rated to withstand 625 PSIG (4,309 kPa) working refrigerant pressure. Refrigerant to water heat exchangers shall be of copper inner water tube and steel refrigerant outer tube design, rated to withstand 625 PSIG (4,309 kPa) working refrigerant pressure and 300 PSIG (2,068 kPa) working water pressure. The refrigerant-to-water heat exchanger shall be "electro-coated" with a low cure cathodic epoxy material a minimum of 0.4 mils thick (0.4 – 1.5 mils range) on all surfaces. The black colored coating shall provide a minimum of 1,000 hours salt spray protection per ASTM B117-97 on all external steel and copper tubing. The material shall be formulated without the inclusion of any heavy metals and shall exhibit a pencil hardness of 2H (ASTM D3363-92A), crosshatch adhesion of 4B-5B (ASTM D3359-95), and impact resistance of 160 in-lbs (184 kg-cm) direct (ASTM D2794-93).

Refrigerant metering shall be accomplished by thermostatic expansion valve only. Expansion valves shall be dual port balanced type with external equalizer for optimum refrigerant metering. Units shall be designed and tested for operating ranges of entering water temperatures from 20° to 120°F (-6.7° to 48.9°C). The reversing valve shall be four-way solenoid activated refrigerant valve, which shall default to heating mode should the solenoid fail to function. If the reversing valve solenoid defaults to cooling mode, an additional low-temperature thermostat must be provided to prevent over-cooling an already cold room.

Units charged with 62 ounces or greater of R-454B shall be supplied with a Refrigerant Detection System (RDS) with sensors to be strategically placed within the cabinet. In the event of a refrigerant leak, the RDS disables compressor operation, and the unit blower runs to disperse any concentration of leaked refrigerant in compliance with UL 60335-2-40 safety standards for flammable refrigerants. **Units charged with 62 ounces or greater of R-454B that do not have an RDS shall not be acceptable.**

ELECTRICAL

- Option:** The unit will be supplied with cupro-nickel coaxial water to refrigerant heat exchanger.
- Option:** The refrigerant-to-air heat exchanger shall be tin-plated.
- Option:** The Refrigerant Detection System (RDS) package shall consist of the RDS module and sensors to be strategically placed within the cabinet. In the event of a refrigerant leak, the RDS triggers an alert through the DDC control system, disables compressor operation, and the unit blower runs to disperse any concentration of leaked refrigerant in compliance with UL 60335-2-40 safety standards for flammable refrigerants (Optional for sizes 006-048).

DRAIN PAN

The drain pan shall be constructed of a polymer material that inhibits corrosion. Drain outlet shall be connected from pan using provided polymer coupling and clamps that meet UL 2043 as required for discrete products by the IMC and UMC when located in a plenum. If galvanized-steel drain pan is used, it shall be fully insulated on both sides and must meet the stringent 1,000-hour salt spray test per ASTM B117. Drain outlet shall be located at pan as to allow unobstructed drainage of condensate. Drain outlet shall be connected from pan directly to a rubber coupling. **No hidden internal tubing extensions from pan outlet extending to unit casing (that can create drainage problems) will be accepted.** The unit as standard will be supplied with solid-state electronic condensate overflow protection. Mechanical float switches will NOT be accepted.

- Option:** The unit shall be supplied with stainless-steel drain pan with ¾-inch MPT plumbing connection. The stainless steel drain pan shall be fully insulated on all sides.

A control box shall be located within the unit compressor compartment and shall contain a 50VA transformer, 24V activated, two or three-pole compressor contactor, terminal block for thermostat wiring and solid-state controller for complete unit operation. The control box on sizes 006 through 060 shall have a door to protect the internal components. The entire control box shall be capable of rotating out of the unit to allow access to the components behind the control box. Low voltage wires shall enter the box through a hole in the lower left side and high voltage wires shall enter the box through a hole in the upper left side. Reversing valve and blower motor wiring shall be routed through this electronic controller. Units shall be name-plated for use with time delay fuses or HACR circuit breakers. Unit controls shall be 24V and provide heating or cooling as required by the remote thermostat/sensor.

- Option:** Disconnect Switch, Non-Fused, classified as motor disconnect.

ENHANCED SOLID STATE CONTROL SYSTEM (CXM2)

Units shall have a solid-state control system. Units utilizing electro-mechanical control shall not be acceptable. The control system microprocessor board shall be specifically designed to protect against building electrical system noise contamination, EMI, and RFI interference. The control system shall interface with a heat pump type thermostat. The control system shall have the following features:

- Anti-short cycle time delay on compressor operation.
- Random start on power-up mode.
- Low-voltage protection.
- High-voltage protection.

- e. Unit shutdown on high- or low-refrigerant pressures.
- f. Unit shutdown on low water temperature.
- g. Condensate-overflow electronic protection.
- h. Option to reset unit at thermostat or disconnect.
- i. Automatic intelligent reset. Unit shall automatically reset the unit 5 minutes after trip if the fault has cleared. If a fault occurs three times sequentially without thermostat meeting temperature, then lockout requiring manual reset will occur.
- j. Ability to defeat time delays for servicing.
- k. The low-pressure switch shall not be monitored for the first 120 seconds after a compressor start command to prevent nuisance safety trips.
- l. 24V output to cycle a motorized water valve or other device with compressor contactor.
- m. Unit Performance Sentinel (UPS). The UPS warns when the heat pump is running inefficiently.
- n. Water coil low-temperature sensing (selectable for water or anti-freeze).
- o. Air coil low-temperature sensing.
- p. Minimized reversing-valve operation (Unit control logic shall only switch the reversing valve when cooling is demanded for the first time. The reversing valve shall be held in this position until the first call for heating, ensuring quiet operation and increased valve life.
- q. Emergency-shutdown contacts.
- r. Entering- and leaving-water temperature sensing.
- s. Leaving-air temperature sensing.
- t. Compressor-discharge temperature sensing.

NOTE: Units not providing the eight safety protections of anti-short cycle, low voltage, high voltage, high refrigerant pressure, low pressure (loss of charge), air coil low temperature cut-out, water coil low temperature cut-out, and condensate overflow protections will not be accepted.

When CXM2 is connected to the AWC Thermostat or handheld service tool, the installer/service technician can; check DIP switch S2 settings; run operation modes manually; check all physical inputs from thermostat and refrigerant pressure switches status, (Y1, Y2, W, O, G, H, ESD, NSB, OR, HP switch, and LOC switch); current or at time of fault the following temperatures - water coil (LT1), air coil (LT2), compressor discharge, leaving air, leaving water, entering water and control voltage; record last five faults, list possible reasons, and clear faults. When the AWC Thermostat is used this same functionality can be viewed and adjusted remotely in the web portal or mobile app. Systems not providing remote access, diagnosis, and adjustment functionality will not be accepted.

Option: Enhanced Solid State Control System (DXM2.5)

This control system is a communicating controller.

Control shall have the features of CXM2 Communicating Controls along with the following expanded features:

- a. Removable thermostat connector.
- b. Night setback control.
- c. Random start on return from night setback.
- d. Override temperature control with 2-hour timer for room occupant to override setback temperature at the thermostat.
- e. Dry contact night setback output for digital night setback thermostats.
- f. Ability to work with heat pump or heat/cool (Y, W) type thermostats.
- g. Ability to work with heat pump thermostats using O or B reversing valve control.
- h. Boilerless system heat control at low loop water temperature.
- i. Ability to allow up to three units to be controlled by one thermostat.

- j. Relay to operate an external damper.
- k. Relay to start system pump.
- l. 75VA control transformer. Control transformer shall have load side short circuit and overload protection via a built-in circuit breaker.

NOTE: Units not providing the eight safety protections of anti-short cycle, low voltage, high voltage, high refrigerant pressure, low pressure (loss of charge), air coil low temperature cut-out, water coil low temperature cut-out, and condensate overflow protection for both drain pans will not be accepted.

When DXM2.5 is connected to the AWC Thermostat or handheld service tool, the installer/service technician can; check and set CFM; check DIP switch S1, S2, and S3 settings; run operation modes manually; check all physical inputs from thermostat and refrigerant pressure switches status, (Y1, Y2, W, O, G, H, ESD, NSB, OR, HP switch, and LOC switch); current or at time of fault the following temperatures - water coil (LT1), air coil (LT2), compressor discharge, leaving air, leaving water, entering water and control voltage; record last five faults, list possible reasons, and clear faults. When the AWC Thermostat is used this same functionality can be viewed and adjusted remotely with the only portal or mobile app. **Systems not providing remote access, diagnosis, and adjustment functionality will not be accepted.**

DIGITAL NIGHT SETBACK WITH PUMP RESTART (DXM2.5 W/ ATP32U03C/04C, AWC99U01)

The unit will be provided with a Digital Night Setback feature using an accessory relay on the DXM2.5 with an ATP32U03C/04C or AWC Thermostat and an external, field-provided time clock. The external time clock will initiate and terminate the night setback period. The thermostat will have a night setback override feature with a programmable override time period. An additional accessory relay on the unit DXM2.5 energizes the building loop pump control for the duration of the override period. **Note: This feature requires additional low voltage wiring. Consult Application Drawings for details.**

REMOTE SERVICE SENTINEL (CXM2/DXM2.5)

The solid-state control system shall communicate with applicable thermostats to display (at the thermostat) the unit status, fault status, and specific fault condition, as well as retrieve previously stored fault that caused unit shutdown. The Remote Service Sentinel allows building maintenance personnel or service personnel to diagnose unit from the wall thermostat. The control board shall provide a signal to the thermostat, indicating a lockout. A detailed message shall be provided at the communicating thermostat or service tool and specific fault status such as over/under voltage fault, high pressure fault, low pressure fault, low water temperature fault, condensate overflow fault, etc. **Units that do not provide this remote service sentinel shall not be acceptable.**

Option: MPC (Multiple Protocol Control) Interface System

Units shall have all the features listed above (either CXM2 or DXM2.5) and the control board will be supplied with a Multiple Protocol interface board. Available protocols are BACnet MS/TP, Modbus, or Johnson Controls N2. The choice of protocol shall be field selectable/changeable via the use of a simple selector switch. **Protocol selection shall not require any additional programming or special external hardware or software tools.** This will permit all units to be daisy chain connected by a two-wire twisted pair shielded cable. The following points must be available at a central or remote computer location:

- a. Space temperature.
- b. Leaving-water temperature.
- c. Discharge-air temperature.
- d. Command-of-space temperature setpoint.
- e. Cooling status.
- f. Heating status.
- g. Low-temperature sensor alarm.
- h. Low-pressure sensor alarm.
- i. High-pressure switch alarm.
- j. Condensate-overflow alarm.
- k. High-/low-voltage alarm.

FIELD-INSTALLED OPTIONS

- l. Fan "ON/AUTO" position of space thermostat as specified above.
- m. Unoccupied / occupied command.
- n. Cooling command.
- o. Heating command.
- p. Fan "ON/AUTO" command.
- q. Fault-reset command.
- r. Itemized fault code revealing reason for specific shutdown fault (any one of seven).

This option also provides the upgraded 75VA control transformer with load side short circuit and overload protection via a built-in circuit breaker.

WARRANTY

ClimateMaster shall warranty equipment for a period of 12 months from startup or 18 months from shipping (whichever occurs first).

Option: Extended 4-year compressor warranty covers compressor for a total of 5 years.

Option: Extended 4-year refrigeration circuit warranty covers coils, reversing valve, expansion valve and compressor for a total of 5 years.

Option: Extended 4-year control board warranty covers the CXM2/DXM2.5 for a total of 5 years.

Hose Kits

All units shall be connected with hoses. The hoses shall be braided stainless steel; fire-rated hoses complete with adapters. Only fire rated hoses will be accepted.

Valves

The following valves are available and will be shipped loose:

- a. Ball valve; bronze material, standard port full flow design, FPT connections.
- b. Ball valve with memory stop and PT port.
- c. "Y" strainer with blowdown valve; bronze material, FPT connections.
- d. Motorized water valve; slow acting, 24V, FPT connections.

Hose Kit Assemblies

The following assemblies ship with the valves already assembled to the hose described:

- a. Supply and return hoses having ball valve with PT port.
- b. Supply hose having ball valve with PT port; return hose having automatic flow regulator valve with PT ports, and ball valve.
- c. Supply hose having "Y" strainer with blowdown valve, and ball valve with PT port; return hose having automatic flow regulator with PT ports, and ball valve.
- d. Supply hose having "Y" strainer with blowdown valve, and ball valve with PT port; return hose having ball valve with PT port.

THERMOSTATS

The thermostat shall be a ClimateMaster mechanical or electronic type thermostat as selected below with the described features:

a. **iGate 2 Communicating (AWC) Thermostat (AWC99U01)**

An electronic communicating web-enabled touchscreen thermostat shall be provided. The thermostat shall offer three stages of heating and two stages of cooling with precise temperature control and have a four-wire connection to the unit. The thermostat shall be capable of manual or automatic change-over operation and shall operate in standard or programmable mode. An integrated humidity control feature shall be included to control a humidifier and/or a dehumidifier. The thermostat shall include a utility demand reduction feature to be initiated by an independent time program or an external input. The thermostat shall provide access to via the web portal or mobile application to include temperature adjustment, schedule adjustment including occupied/unoccupied, entering-water temperature, leaving-water temperature, water-coil temperature, air-coil temperature, leaving-air temperature, and compressor-discharge temperature. A graphical system layout to be provided with real-time operating mode information of the temperature sensors for easy diagnostics. The thermostat shall display system faults with probable cause and troubleshooting guidance. The system shall provide in clear language the last five faults, time of faults, operating temps at time of fault, and possible reasons for the fault. The thermostat shall provide access for immediate manual control of all outputs via the web portal/mobile application for rapid troubleshooting.

b. **Single-Stage Digital Auto or Manual Changeover (ATA11U01)**

The thermostat shall be a single-stage, digital, auto or manual changeover with HEAT-OFF-COOL-AUTO system switch and fan ON-AUTO switch. The thermostat shall have an LCD display with temperature and setpoint(s) in °F or °C. The thermostat shall provide permanent memory of setpoint(s) without batteries. A fault LED shall be provided to display specific fault condition. The thermostat shall provide temperature display offset for custom applications.

c. **Multi-stage Manual Changeover Programmable 5/2 Day (ATP21W02)**

The thermostat shall be 5-day/2-day programmable (with up to four setpoints per day), multi-stage (2H/1C), manual changeover with HEAT-OFF-COOL-EM HEAT system settings and fan ON-AUTO settings. The thermostat shall have an LCD display with temperature, setpoint(s), mode, and status indication. The temperature indication shall be selectable for °F or °C. The thermostat shall provide permanent memory of setpoint(s) without batteries. The thermostat shall provide convenient override feature to temporarily change setpoint.

d. Multi-stage Automatic or Manual Changeover Programmable 7-Day (ATP32U03C)

The thermostat shall be 7-day programmable (with up to four setpoints per day), multi-stage (3H/2C), automatic or manual changeover with HEAT-OFF-COOL-AUTO-EM HEAT system settings and fan ON-AUTO settings. The thermostat shall have a blue backlit dot matrix LCD display with temperature, setpoints, mode, and status indication. The temperature indication shall be selectable for °F or °C. Time display shall be selectable for 12- or 24-hour clock. Fault identification shall be provided to simplify troubleshooting by providing specific unit fault at the thermostat with red backlit LCD during unit lockout. The thermostat shall provide permanent memory of setpoints without batteries. The thermostat shall provide heating-setpoint range limit, cooling-setpoint range limit, temperature display offset, keypad lockout, dead-band range setting, and inter-stage differential settings. The thermostat shall provide progressive recovery to anticipate time required to bring space temperature to the next programmed event. The thermostat shall provide an installer setup for configuring options and for setup of servicing contractor name and contact information. The thermostat shall allow the use of an accessory remote and/or outdoor-temperature sensor (AST008). Thermostat navigation shall be accomplished via five buttons (up/down/right/left/select) with menu-driven selections for ease of use and programming.

e. Multi-stage Automatic or Manual Changeover Programmable 7-Day with Humidity Control (ATP32U04C)

The thermostat shall be 7-day programmable (with up to four setpoints per day), multi-stage (3H/2C), automatic or manual changeover with HEAT-OFF-COOL-AUTO-EM HEAT system settings and fan ON-AUTO settings. Separate dehumidification and humidification setpoints shall be configurable for discreet outputs to a dehumidification option and/or an external humidifier. Installer configuration mode shall allow the thermostat to operate with EC fan dehumidification mode via settings changes.

The thermostat shall have a blue backlit dot matrix LCD display with temperature, relative humidity, setpoints, mode, and status indication. The temperature indication shall be selectable for °F or °C. Time display shall be selectable for 12- or 24-hour clock. Fault identification shall be provided to simplify troubleshooting by providing specific unit fault at the thermostat with red backlit LCD during unit lockout. The thermostat shall provide permanent memory of setpoints without batteries. Thermostat shall provide heating setpoint range limit, cooling setpoint range limit, temperature display offset, keypad lockout, dead-band range setting, and inter-stage differential settings. The thermostat shall provide progressive recovery to anticipate time required to bring space temperature to the next programmed event. The thermostat shall provide an installer setup for configuring options and for setup of servicing contractor name and contact information. The thermostat shall allow the use of an accessory remote and/or outdoor temperature sensor (AST008). Thermostat navigation shall be accomplished via five buttons (up/down/right/left/select) with menu-driven selections for ease of use and programming.

f. CM100 – Multi-stage Automatic or Manual Changeover digital thermostat (ATA32V01)

Multi-stage (3H/2C), automatic or manual changeover with HEAT-OFF-COOL-AUTO-EM HEAT system settings and fan ON-AUTO settings. The thermostat shall have a green backlit LED display with temperature, setpoints, mode, and status indication via a green (cooling) or red(heating) LED. The temperature indication shall be selectable for °F or °C. Time display shall be selectable for 12- or 24-hour clock. The thermostat shall provide permanent memory of setpoints without batteries. The thermostat shall provide heating-setpoint range limit, cooling-setpoint range limit, temperature display offset, keypad lockout, dead-band range setting, and inter-stage differential settings. The thermostat shall provide progressive recovery to anticipate time required to bring space temperature to the next programmed event. The thermostat shall provide an installer setup for configuring.

ClimateMaster works continually to improve its products. As a result, the design and specifications of each product at the time of order may be changed without notice and may not be as described herein. Please contact ClimateMaster's Customer Service Department at 800-299-9747 for specific information on the current design and specifications. Statements and other information contained herein are not express warranties and do not form the basis of any bargain between the parties, but are merely ClimateMaster's opinion or commendation of its products. The latest version of this document is available at www.climatemaster.com. Engineered and assembled in the USA. © ClimateMaster, Inc. All Rights Reserved 2024

Thermostat navigation shall be accomplished via four buttons (Mode/fan/down/up) with menu-driven selections for ease of use and programming.

g. CM300 – Multi-stage, Automatic or Manual Changeover, 7-day Programmable with Wi-Fi and Humidity Control (AVB32V02C/R)

The residential version shall be 7-day programmable with up to four setpoints per day. The commercial version shall be 7-day programmable with four occupied/unoccupied periods per day with up to 4-hour override. Multi-stage (3H/2C), automatic or manual changeover with HEAT-OFF-COOL-AUTO-EM HEAT system settings and fan ON-AUTO settings, Wi-Fi, pre-occupancy purge fan option, nighttime control of display backlight, bi-color LED indicates a heating or cooling demand, keypad lock, title 24 compliant, openADR2.0b certified with Skyport web portal. Compatible with condensate-overflow warning systems – lockout compressor with message on.

h. CM500 – Color-Touchscreen Display, Multi-stage, Automatic or Manual Changeover, 7-day Programmable with Wi-Fi and Humidity Control (AVB32V03C/R)

The thermostat shall have color-resistive touchscreen display with space temperature, relative humidity, setpoints, mode, status indication and local weather (if connected to Wi-Fi). Residential version shall be 7-day programmable with up to four setpoints per day. The commercial version shall be 7-day programmable with four occupied/unoccupied periods per day with up to 4-hour override. Multi-stage (3H/2C), automatic or manual changeover with HEAT-OFF-COOL-AUTO-EM HEAT system settings and fan ON-AUTO settings, Wi-Fi, pre-occupancy purge fan option, customizable screen saver and background displays, indicator-on display indicates a heating or cooling demand, set-point lock, title 24 compliant, openADR2.0b certified with Skyport web portal. Compatible with condensate-overflow warning systems – lockout compressor with message on the display.

Capable of being monitored by third-party software. Compatible with AST014 Wi-Fi remote sensor. Configurator mobile app or web portal for easy setup. Separate dehumidification and humidification setpoints shall be configurable for discreet outputs to a dehumidification option and/or an external humidifier. The temperature indication shall be selectable for °F or °C. Time display shall be selectable for 12- or 24-hour clock. The thermostat shall provide permanent memory of setpoints without batteries. The thermostat shall provide heating setpoint-range limit, cooling setpoint-range limit, temperature display offset, dead-band range setting, and inter-stage differential settings. The thermostat shall provide progressive recovery to anticipate time required to bring space temperature to the next programmed event. The thermostat shall provide access to a web portal and mobile app for installer setup for configuring options. The thermostat shall have menu-driven selections for ease-of-use and programming.

DDC SENSORS

ClimateMaster wall mounted DDC sensor to monitor room temperature and interfaces with optional interface system described above. Several types as described below:

- Sensor only with no display (MPC).
- Sensor with setpoint adjustment and override (MPC only).
- Sensor with setpoint adjustment and override, LCD display, status/fault indication (MPC).

NOTICE! This product specification document is furnished as a means to copy and paste ClimateMaster product information into project specification. It is not intended to be a complete list of product requirements. This document is an excerpt from the product submittal and must not be used without consulting the complete product submittal. For complete product installation and application requirements, please consult the complete product submittal. ClimateMaster is not responsible for misuse of this document or a failure to adequately review specific requirements in the product catalog.

Revision History

Models:
SC
006-060

Date	Section	Description
01/13/24	Correction Tables	Updated Cooling Corrections data
	Electrical Data	Updated data
12/17/24	Model Nomenclature, Performance Data, Blower Data, Physical Data, Dimensional Data, Electrical Data	Added size 041 content
11/22/24	All	Updated naming conventions for CXM2, DXM2.5, and AWC Thermostat
	Dimensional Data	Updated dimensional data
10/18/24	Blower Performance	Added a note concerning approved installation altitudes
10/03/24	Performance Data	Updated Cooling EAT temperatures
09/10/24	Engineering Specs	Updated Unit Maximum Water Working Pressure
08/08/24	Minimum Installation Area	Updated Minimum Installation Area data
	Physical Data	Updated Unit Maximum Water Working Pressure
07/11/24	Blower Data, Dimensional Data, Minimum Installation Area, Performance Data	Updated AHRI ratings
		Updated performance data for size 042
		Updated minimum installation area tables and values
		Updated blower data for sizes 006, 012, and 042
06/11/24	Performance Data, Electrical Data	Updated AHRI ratings
		Updated performance data for sizes 006-060
		Updated electrical data
		Updated dimensional data for sizes 006-018
03/18/24	Model Nomenclature	Updated voltage options
03/06/24	All	Added sizes 006-018
01/18/24	All	Created



A NIBE GROUP MEMBER

7300 SW 44th St | Oklahoma City, OK 73179

Phone: 800.299.9747

www.climatemaster.com



ClimateMaster works continually to improve its products. As a result, the design and specifications of each product at the time of order may be changed without notice and may not be as described herein. Please contact ClimateMaster's Customer Service Department at 800-299-9747 for specific information on the current design and specifications. Statements and other information contained herein are not express warranties and do not form the basis of any bargain between the parties, but are merely ClimateMaster's opinion or commendation of its products. The latest version of this document is available at www.climatemaster.com. Engineered and assembled in the USA. © ClimateMaster, Inc. All Rights Reserved 2024